

# INSTALLATION & OPERATION MANUAL



## 7,000 lbs Capacity VERSALIFT ATEVERSALIFT-7MRP



**ATLAS Automotive Equipment**  
**[www.AtlasAutomotiveEquipment.ca](http://www.AtlasAutomotiveEquipment.ca)**  
**(866) 284-8604**

1. Introduction	1
1.1 Execution	1
1.2 Information about this manual	2
2. Safety	3
2.1 Warnings	4
2.2 Hazard sign	4
2.3 Other symbols	5
2.4 User limitations	5
2.5 Device description	5
2.6 Intended use	6
2.7 Safety devices	7
2.8 Regular inspection of the lift	7
2.9 Accident prevention regulations	7
3. Delivery	9
3.1 Main components of the lift	10
3.2 Main components of the foot pedal controller	11
4. Assembly and installation	12
4.1 Foundation	12
4.2 Operation of the lift	13
4.3 Before the first start-up	14
4.4 Connecting the foot pedal controller	15
4.5 Filling with hydraulic oil / Checking the oil level	17
4.6 Support arms adjustment	18
5. Lift operation	19
5.1 Positioning vehicles on the lift	19
5.2 Raising and lowering the vehicle	20
6. Maintenance and care	23
6.1 Maintenance schedule	23

7. Troubleshooting / Malfunctions	24
8. Technical data	25
8.1 Hydraulic and pneumatic diagram	25
8.2 Spare parts list	26
9. Waste disposal and environmental protection	26
10. List of figures	27
11. List of tables	27
12. Inspection log with templates	28
12.1 Inspection review	29
12.2 Main sheet	30
12.3 General arrangement drawing	31
12.4 First start-up	32
12.5 Regular safety check	34
12.6 Extraordinary security check	36

# 1. Introduction

Thank you for the trust you have placed in our vehicle lift. You have purchased a very high quality product. It has been very carefully designed. However, if you are not satisfied with something do not hesitate to contact us.

[www.AtlasAutoEquipment.ca](http://www.AtlasAutoEquipment.ca)  
[customercare@atlasautoequipment.ca](mailto:customercare@atlasautoequipment.ca)  
Tel: 866-284-8604

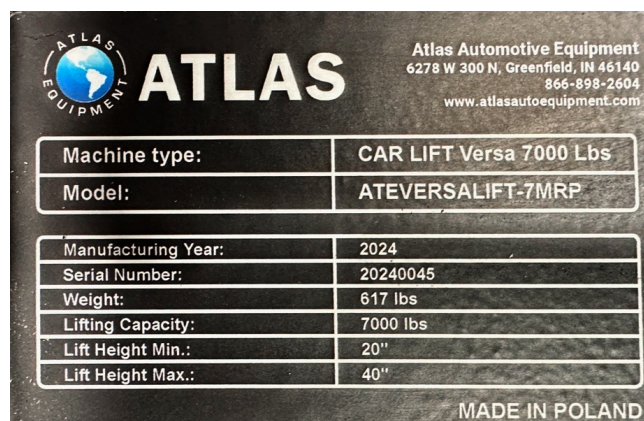
We speak English and French.

We wish you a lot of satisfaction with operation of your vehicle lift.

## 1.1 Execution

This user's manual is valid for the VERSALIFT-7MRP with pneumatic pump and capacity 7,000 lbs. An external compressed air supply of 6-7 bar is required for operation of the lift.

The exact model designation, serial number and year of manufacture can be found on the rating plate on the base frame.



The image shows a metal rating plate for an Atlas automotive lift. It features the Atlas logo (a globe with 'ATLAS EQUIPMENT' text) and the company name 'ATLAS' in large letters. To the right, it lists the company name 'Atlas Automotive Equipment', address '6278 W 300 N, Greenfield, IN 46140', phone number '866-898-2604', and website 'www.atlasautoequipment.com'. Below this is a table with technical specifications. At the bottom right, it says 'MADE IN POLAND'.

Machine type:	CAR LIFT Versa 7000 Lbs
Model:	ATEVERSALIFT-7MRP
Manufacturing Year:	2024
Serial Number:	20240045
Weight:	617 lbs
Lifting Capacity:	7000 lbs
Lift Height Min.:	20"
Lift Height Max.:	40"

MADE IN POLAND

## 1.2 Information about this manual

Read this manual carefully before using the lift for the first time. In this way, malfunctions and defects caused by incorrect or improper use can be avoided.

The user's manual contains:

- Important safety regulations
- Hints on operation of the lift
- Instructions for maintenance and care of the lift
- Assistance in troubleshooting
- Review of our accessories
- Review the necessary tests in the inspection log

This user's manual describes the proper use of the lift. Therefore, it should be kept near the lift for quick reference. User's manual is part of the lift and should be handed over to new owner with the inspection log in the event of sale or further commissioning.

Remember to follow all safety instructions. These can be found in the Safety section.

Furthermore, safety instructions are repeated at appropriate places in the user's manual. The user is responsible for following all safety regulations in all cases. All safety regulations are in accordance with applicable European Union directives and regulations. Furthermore, additional national regulations may require to be considered.

The national regulations and laws of the given country shall apply while using the lift outside the European Union. Depending on area of use it is also required to consider the national regulations and laws. Please note that safe operation of the lift is guaranteed only if the original spare parts are used.

## 2. Safety

The lift can only be used after you have thoroughly read and understood these manual. Unauthorized modifications in the lift and its safety devices are prohibited. ATLAS AUTOMOTIVE EQUIPMENT shall not be responsible for any damages resulting from violating of this regulations.

The following hints should be observed:

- Risk of crushing.
- Use personal protection equipment.
- Observe all accident prevention regulations.
- We recommend to create a 3-meter safety zone around the lift.
- Make sure that the lift does not obstruct the exit paths. This is especially important when the vehicle is placed on a lift.
- Make sure that there are during the lifting and lowering of the lift there are no dangerous situations in the safety zone. If this happens, stop the lift immediately and remedy the cause of the dangerous situation. Dangerous situations can include people or animals staying in the safety zone of the lift.
- Make sure there are no objects under the lift when it is raised.
- Do not exceed the permissible load capacity. Observe the information given on the rating plate.
- Make sure that vehicle weight and load distribution in lifting points conform to the recommendations given in this user's manual.
- Make sure that disassembly of the vehicle parts will not cause shifting of the load/centre of gravity so that the required limits are no longer observed.
- Secure the lift in lifted position lifting it only to the next safety catch and installing the pin lock using a safety pin.
- Depressurize the lift in case of failure or during maintenance and repair works. To depressurize the lift, disconnect the air hose from the connector.
- Check for leaking hydraulic hoses.
- Only original spare parts should be used.

## 2.1 Warnings

### **DANGER**

This information alerts you about dangerous situation. Failure to observe this information could result in death or serious injury.

### **WARNING**

This information alerts you about dangerous situation. Failure to follow this information may result in death or serious injury.

### **CAUTION**

This information alerts you about dangerous situation. Failure to observe this information may result in moderate or minor injury.

## 2.2 Hazard sign

### **NOTE**



This information warns of environmental pollution. Spills may cause short- or long-term damages to the environment. Never dispose of into sewage or with household waste.

## 2.3 Other symbols



### **HINT**

Wear protective glasses.  
This protects against eye injuries.



### **NOTE**

This information warns of a possible situation that could cause property damage if not avoided.

## 2.4 User limitations

Only person who are 18 years of age or older may be employed to operate the lifts alone. Operators should be trained within the scope of operation of the lift and should prove their competences to their employer. They should receive clear instructions from the employer regarding operation of the lift. Lift operation instruction should be given in writing. By-standers should not stay near the lift.

## 2.5 Device description

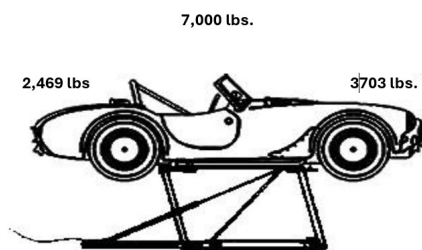
The VERSALIFT-7MRP lift is intended for lifting of the vehicles (passenger cars and small trucks) to the height of approx. 100 cm using hydraulic-pneumatic control. Vehicle wheels are unloaded during lifting (free standing).



## 2.6 Intended use

The VERSALIFT-7MRP lift is used only for lifting of the mechanical vehicles. The vehicles must meet the following conditions:

- The total weight of the vehicle should not exceed 2800 kg.
- The minimum distance between lifting points (wheel track) must be 110 cm. If this distance is shorter, as for classic cars, the load capacity will be reduced. If this is the case, please contact us before using the lift.
- The minimum distance between the lifting points (wheel base) must be 175 cm.
- In general, the vehicles should be lifted only in the longitudinal direction.
- Vehicle load distribution should be balanced or ensured in a ratio not less than 2:3 or not exceeding 3:2.
- it is recommended to position the vehicles so that the hydraulic actuator is facing towards the engine. (Fig. 2)



*Fig. 2: Recommended load distribution*

The VERSALIFT-7MRP lift can lift a vehicle by approx. 100 cm allowing works under the vehicle, e.g. on wheels, brakes, shock absorbers or bodywork. All other possible uses are considered as misuse and Atlas Automotive Equipment shall not be liable for any resulting damages. In particular, it is forbidden to lift persons, animals or objects other than passenger cars.

## **2.7 Safety devices**

The lift is equipped with an emergency stop switch. Lifting and lowering are possible only by triggering the foot pedal. After release of the pedal all motions are immediately stopped.

Furthermore, the lift is equipped with a mechanical safety device. From lifting height of approx. 50 cm two securing rods slide into the safety catches (they are automatically raised during lifting of the lift). This means that in the event of a sudden hydraulic or pneumatic failure, the lift can only descend to the next safety point.

## **2.8 Regular inspection of the lift**

The lift must be inspected at twelve-month intervals by a licensed expert or a specialist based on the inspection log. These checks need to be documented.

See section 12. The inspection log at the end of this user's manual.

## **2.9 Accident prevention regulations**

In particular, the following accident prevention provisions shall apply:

- Rule DGUV 100-500 Operation of work equipment / operation of lifts
- Rule DGUV 308-008 Training and employment of lift operators
- Rule DGUV 308-002 Inspection of lifts
- Rule DGUV 308-003 Lifts inspection log

## 3. Delivery

The lift is delivered in a packaging in the pre-assembled condition.



### **DANGER**



There is a risk of falling when transporting the lift with a crane.  
This can lead to serious injuries with fatal consequences.

- You should never stand under suspended loads.
- Use only approved, suitable lifting equipment.



### **WARNING**



Packaging material is hazardous to children. There is a danger of suffocation.  
Dispose of packaging material according to applicable regulations immediately after unpacking the lift.

#### Scope of delivery:

- Lift
- Foot pedal controller
- 4 support plates with heightadjustable supports
- Towing bar
- Manual and inspection log
- Declaration of conformity

#### Available accessories:

- Plastic ramps for vehicles with low suspension
- Rubber bumper
- Support trestles
- Ramps
- Heavy-duty wheels
- Hose package
- Auxiliary equipment for vehicle loading

### 3.1 Main components of the lift

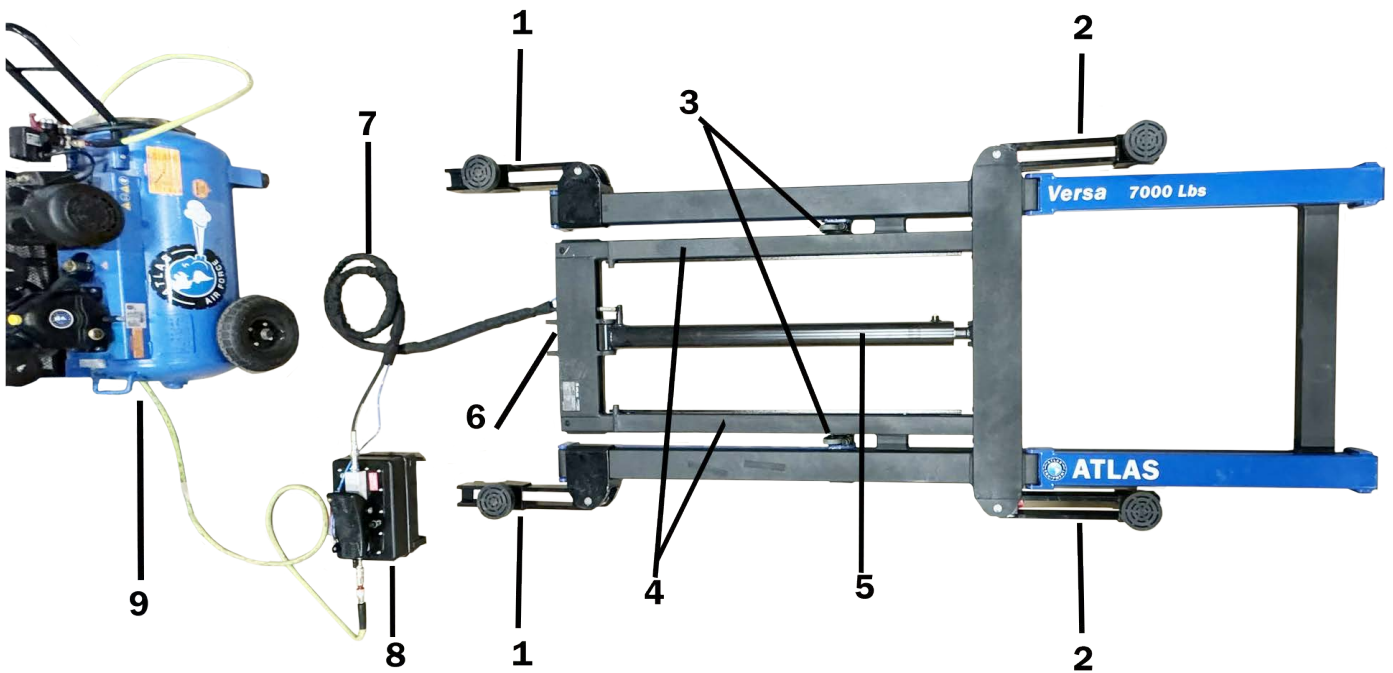


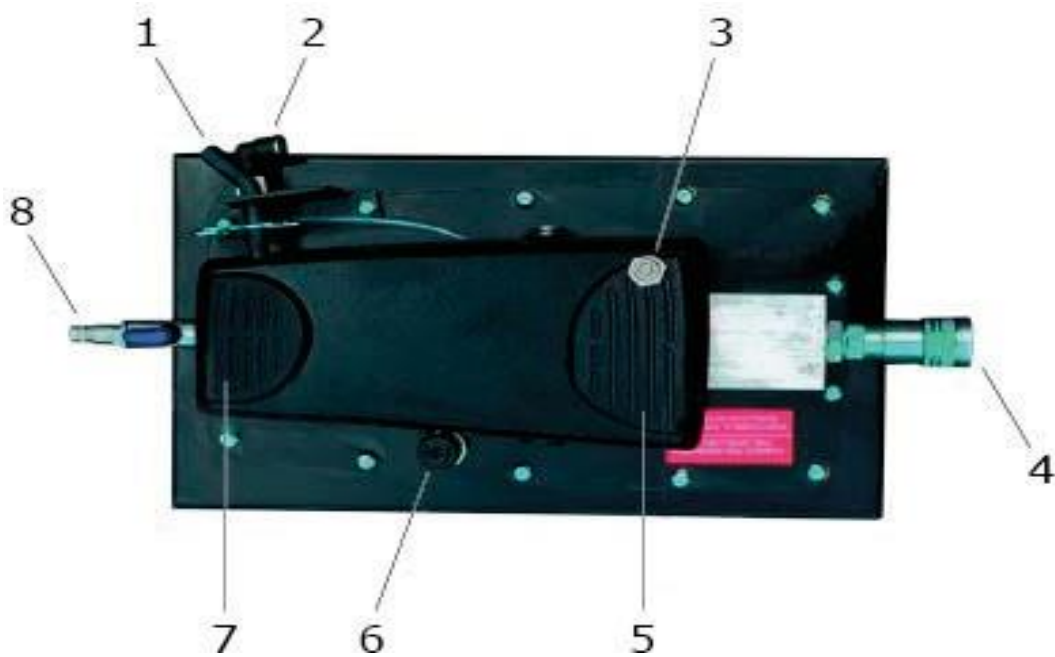
Fig. 3: Main components of the lift

1. Adjustable support arms at the front; right and left
2. Rear support arms; right and left
3. Transport roller with axial mounting screw; right and left
4. Securing bars; right and left
5. Hydraulic actuator
6. Fixing of towing bar
7. Hydraulic hose
8. Foot pedal controller
9. Air Compressor (not included)



Fig. 4: Supporting component with carrier plate

## 3.2 Main components of the foot pedal controller



*Fig. 5: Main components of the foot pedal control unit*

1. Pin lock
2. Compressed air inlet for unblocking
3. Unlocking switch
4. Hydraulic coupler
5. Foot pedal for lowering operation
6. Oil filler connector with dipstick
7. Foot pedal for lifting operation
8. Compressed air connector with ball valve



*Fig. 6: Unlocking switch*

## 4. Assembly and installation



### **DANGER**



If the foundation is too weak or the ground is pitched and a vehicle is being lifted at the same time, there is a risk of the lift tipping over.

Failure to follow the instructions may result in death or serious injury.

Before setting up the lift, check the ground with a level. Check the bearing capacity of the substrate in the relevant documents.



### **DANGER**



There is a risk of the vehicle falling if the lift is moved with the vehicle on it.

Failure to follow the instructions may result in death or serious injury.

Move the lift only when there is no load on the lift.

### 4.1 Foundation

The substrate must be level and dry. Make sure that the substrate can withstand the load (including the vehicle being lifted approx. 3,100 kg).

### **HINT**



Our range of accessories includes special heavy-duty rollers and a hose package for proper operation of the lift with the vehicle on it.

Please contact us.

## 4.2 Operation of the lift

### HINT



If the lift is to be positioned under the vehicle, the lift clearance must be set to a low height in advance. When operating, the lift body should be at a height of approx. 1 cm above the ground.



Fig. 7: Transport rollers



Fig. 8: Fixing of towing bar



Fig. 9: Towing bar

1. Raise the lift to a height of 20-80 cm without load. This height later has a decisive influence on the ground clearance when operating the lift. Depending on the selected mounting height, the clearance is between 1 cm and 8 cm and can therefore be adjusted.
2. To extend the transport rollers, loosen the axial mounting screws on both sides of the lift clockwise with an SW 22 wrench until the transport rollers touch the ground. (Fig. 7)
3. Tighten the mounting screws again.
4. Insert the towing bar into the fastening point. (Fig. 8)
5. Position the lift
6. To retract the transport rollers, turn the two mounting screws counterclockwise until the lift rests completely on the ground again.
7. Remove the towing bar.

## 4.3 Before the first start-up

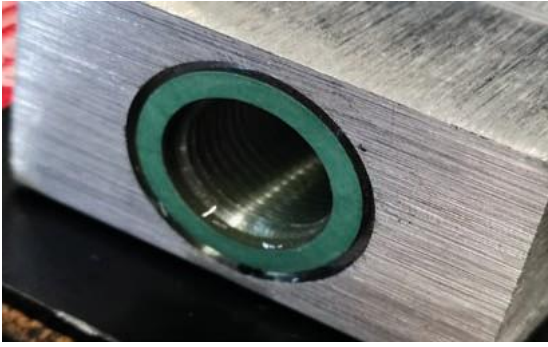


Fig. 10: Hydraulic coupler with transport seal



Fig. 11: Hydraulic coupler with sealing rings and adapter

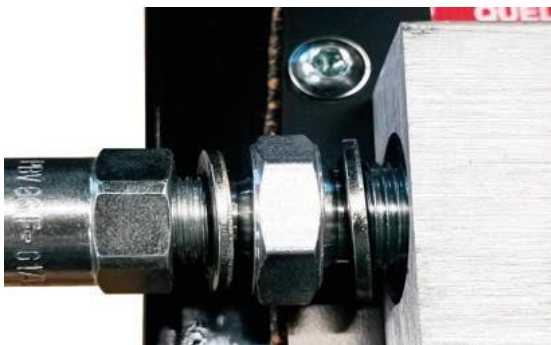


Fig. 12: Installation of the hydraulic coupler

1. Remove the screw on the hydraulic coupler (Fig. 5, position 4) using a SW6 mm Allen wrench. Set the screw aside for use in the future. It will be necessary during further use of the lift.
2. Completely remove the green transport seal. Sealing surface must be clean. (Fig.10)

3. Screw the supplied hydraulic connector and adapter with two sealing rings into the hydraulic coupler. To do this, a SW 19 wrench and a SW 22 mm wrench are required. (Fig. 11 and 12)

4. Tighten the adapter and connector securely.

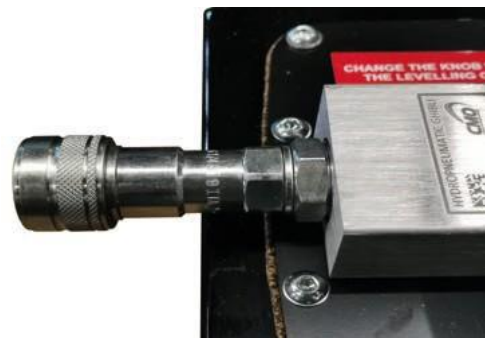


Fig. 13: Hydraulic coupler installed



Fig. 14: Compressed air connector with protective cap

5. Remove the red protection cap from the compressed air connector (Fig.5, position 8). Set the protective cap aside for use in the future. It will be necessary during further use of the lift.





6. Screw the compressed air connection with a seal to the compressed air connector. To do this, a SW 17 mm wrench is required (Fig. 15 and 16)

Fig. 15: Compressed air connection

7. Tighten the connection securely.



Fig. 16: Compressed air connection installed

## 4.4 Connecting the foot pedal controller

### **WARNING**



There is a risk of eye injury. Air or hydraulic fluid escaping under pressure may cause serious injury. This can lead to eye injuries, among other things. Always wear safety glasses when working with compressed air and hydraulic systems. The following operations should be performed only with safety glasses.

### **NOTE**



Regularly check compressed air and hydraulic hose lines and connections for leaks and damage. Damaged components must be immediately replaced with original replacement parts before further use of the lift.

To avoid damage, observe the following sequence:



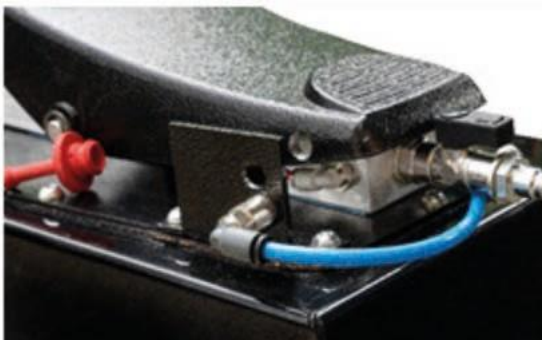
Fig. 17: Foot pedal controller

1. Make sure that the foot pedal controller is no longer connected to the compressed air supply. The device must be depressurized.

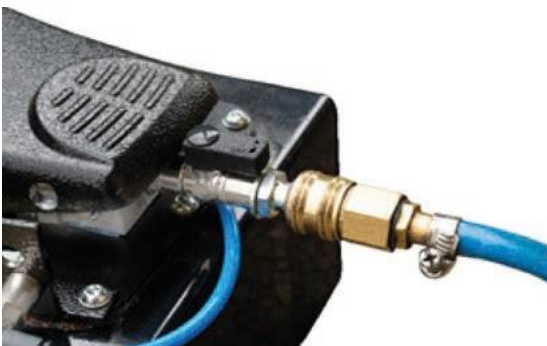


Fig. 18: Hydraulic hose connection

2. First, connect the lift hydraulic line to the foot pedal controller. (Fig. 18)



3. Make sure the blue lock release connection hose is firmly seated in its coupler. (Fig. 19)



4. In the last step, connect the compressed air system hose to the foot pedal controller. (Fig. 20)

## 4.5 Filling with hydraulic oil / Checking the oil level

### NOTE



Hydraulic oil is hazardous to the environment. There is a threat of environmental pollution.

A particular hazard exists for drinking water. Leaking hydraulic oil should be removed immediately and disposed of in an environmentally friendly manner.



### WARNING



Hydraulic oil can cause serious eye injury. This can cause irreversible damage to the eyes.

The following operations should be performed only with safety glasses.

On first start-up, loosen the oil filler connector screw with a 6 mm Allen wrench. Set the screw aside for use in the future. It will be necessary during further use of the lift. (Fig. 21)

Fig. 21: Oil filler connector with dipstick



To check the oil level, proceed as follows (Fig. 21):

1. Screw the dipstick into the oil filler connector.
2. Unscrew the dipstick.
3. Check the oil level on the dipstick.

The oil level must be between minimum and maximum. (Fig. 22)



If the oil level is too low, place a funnel in the oil filler connector and fill with HLP 22 hydraulic oil. The maximum filling quantity is 4.2 litres.

Screw in the dipstick again.

Fig. 22: Measuring dipstick for oil

## 4.6 Support arms adjustment

To lift the vehicle, move the support arms to the position of the vehicle lift points.

All four support arms can be adjusted to 180°.

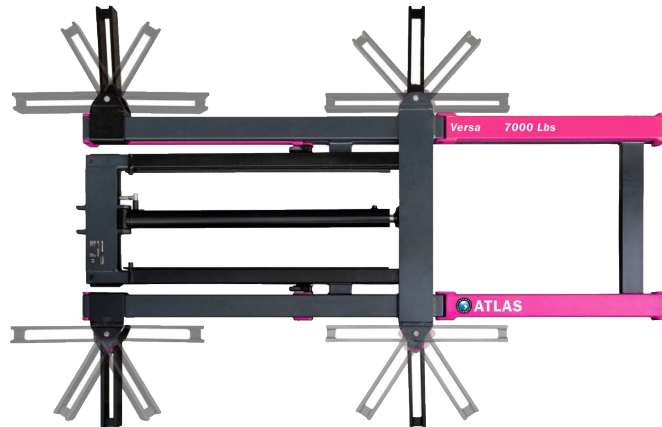


Fig. 23: Adjustment possibilities for support arms



Fig. 24: Unlocking the support arm

1. To unlock the support arm, pull up the red lever located inside the corresponding support arm. (Fig. 24)



Fig. 25: Layout of holes for adjusting the support arms

2. Adjustment of the support arms is done in the same manner as adjustment of the hole pattern. When the red lever is released, the support arm locks into the desired position. (Fig. 25)

# 5. Lift operation

## 5.1 Positioning vehicles on the lift

The lift must rest in the lowered position on the ground. The transport rollers of the lift must be retracted.

Check whether all support arms are folded and whether the support components with support plates are not resting on the support arms. Position the vehicles so that the hydraulic actuator is facing the engine. (Fig. 2)

Carefully drive the vehicle over the lift. Position the vehicle so that all 4 support arms are at the height of the lifting points of the vehicle.

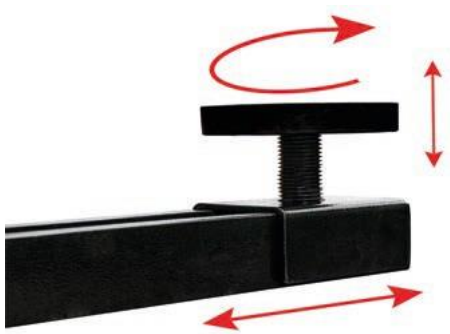


Fig. 26: Support component with support plate on the support arm

1. Tilt the support arms outward.
2. Place the support components with support plates on the support arms.
3. Check whether the support components can be moved and whether the support plates can rotate. (Fig. 26)

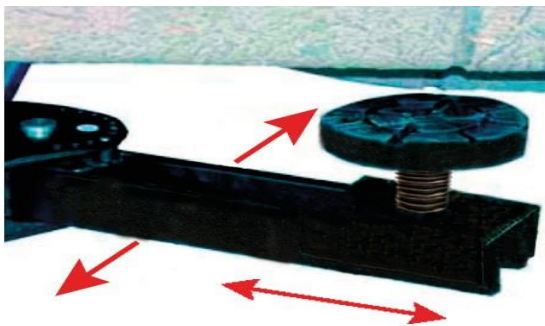


Fig. 27: Setting the support arm and the support component

4. Tilt the support arms with the support components exactly under the vehicle support points.

To correct the distances between the support plates and the lifting points, rotate the support plates as far as necessary.

## 5.2 Raising and lowering the vehicle

### NOTE



For horizontal lifting, make sure that all 4 support members are moved on the support arms by approximately the same distance. In addition, all the support plates should be rotated all the way to the bottom at the beginning. (Fig. 26)

### DANGER



There is an increased risk of crushing. People may become trapped during lifting. This can lead to serious and irreversible injury. There is a risk of losing hands and arms. Do not reach into the lift while operating.



Remember that as the lift moves upward, it simultaneously moves toward the attachment point of the towing bar with the vehicle. A total of 80 cm can be moved forward in this way. The safety distance observed must take this movement into account. (Fig. 28)

Fig. 28: Travel of the lift during upward motion

### DANGER



There is an increased risk of crushing. If the lift falls, people may become trapped underneath it. Failure to follow the instructions may result in death or serious injury. Standing directly underneath a raised vehicle is prohibited. No persons or animals are allowed in the lift safety area.

## **DANGER**



There is a danger of falling.

Vehicles may fall from the lift. People may be trapped.

- No persons are allowed to stay on or in the lift.
- No people can be in or on the vehicle while it is being lifted.
- When disassembling vehicle parts, make sure that the centre of gravity is not shifted.
- Ensure the correct load distribution (3:2 / 2:3) as shown in section 2.6 Intended use (Fig. 2).

## **HINT**



To avoid damaging the hydraulic hose, be careful not to pinch it when lowering.

## **HINT**



Check the operation of the lock release before each use. The release switch unlocks the safety bars.



If there is a pin lock on the foot pedal control assembly, remove it. (Fig. 29)

*Fig. 29: Pin lock with safety cotter*

## NOTE



Secure the lift to prevent accidental lowering:

- When lifting, always raise the lift to the nearest safety catch.
- After raising, put a pin lock on the control unit. (Fig. 29)

## NOTE



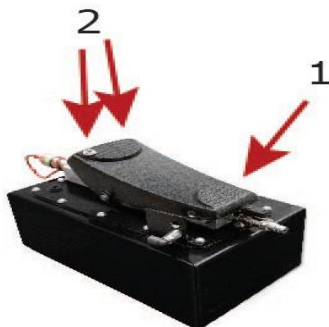
Do not stand on the foot pedal with your entire body weight.

This can cause damage to the control valves. The foot pedal can be operated by applying light foot pressure.

## NOTE



Avoid jerky raising and lowering.



To lift the vehicle, operate the foot pedal on the compressed air side (1).

To lower the vehicle, operate the foot pedal on the hydraulic side simultaneously with the unlock switch (2).

(Fig. 30)

Fig. 30: Foot pedal



## 6. Maintenance and care

The lift is a low maintenance product. Nevertheless, some maintenance and care is necessary. Adherence to maintenance intervals and care instructions is part of proper lift operation. ATLAS Auto Equipment is not responsible for damage caused by negligent maintenance and care.

### 6.1 Maintenance schedule

The information is for commercial use.

Longer intervals may be appropriate for personal use. In that case, inspect the lift before and after use, and perform maintenance if necessary.

Every day	Every two weeks	Every year
Check tightness of hydraulic and pneumatic systems.	Lubricate with grease all moving parts, especially the joints.	Replace pneumatic hoses. For private use, a longer period of use is possible.
Remove large amounts of debris from the lift.		Change the hydraulic oil and oil filter. Use only HLP 22 hydraulic oil. The filling quantity is 4.2 litres.
Remove debris from the lift actuator piston rod.		
Check the support plate for any damage.		
Remove debris from the safety catches.		

Tab. 1: Maintenance plan

Replace the hydraulic hose supply line every six years, regardless of actual frequency of use.

## 7. Troubleshooting / Malfunctions

The following table lists some of the malfunctions that may occur during operation. Troubleshooting should only be performed by authorised personnel. Only original spare parts should be used. ATLAS Auto Equipment is not responsible for lack of expertise or use of unapproved spare parts. This applies in particular to damage to people, animals or material damage. In the event of a failure, the manufacturer's technical service must be notified immediately so that further action can be agreed.

<b>Disturbance</b>	<b>Cause</b>	<b>Removal</b>
The lift does not raise, but the pump works.	- no oil in the tank - - clogged oil filter - worn or	- refill oil (HLP 22) - clean - repair
The lifter does not perform a fully continuous lift cycle.	- Oil level below minimum	- refill oil (HLP 22)
The lift lifts unevenly.		•- vent the tank through the vent screw
When the lifting is completed, the lift moves toward the safety device.	- vent valve jammed - safety valve blocked of the actuator	- clean/unblock the vent valve - perform cleaning or replacement

Tab. 2: Troubleshooting

## 8. Technical data

Lift capacity	7,000 lbs.
Pneumatic pressure	6-7 bar
Dead weight	approx. 660 lbs.
Max. lifting height	approx. 97,5 / 107 cm
Min. lifting height	approx. 36 cm
Min. assembly height	approx. 10,5 cm

Tab. 3: Technical data

### 8.1 Hydraulic and pneumatic diagram

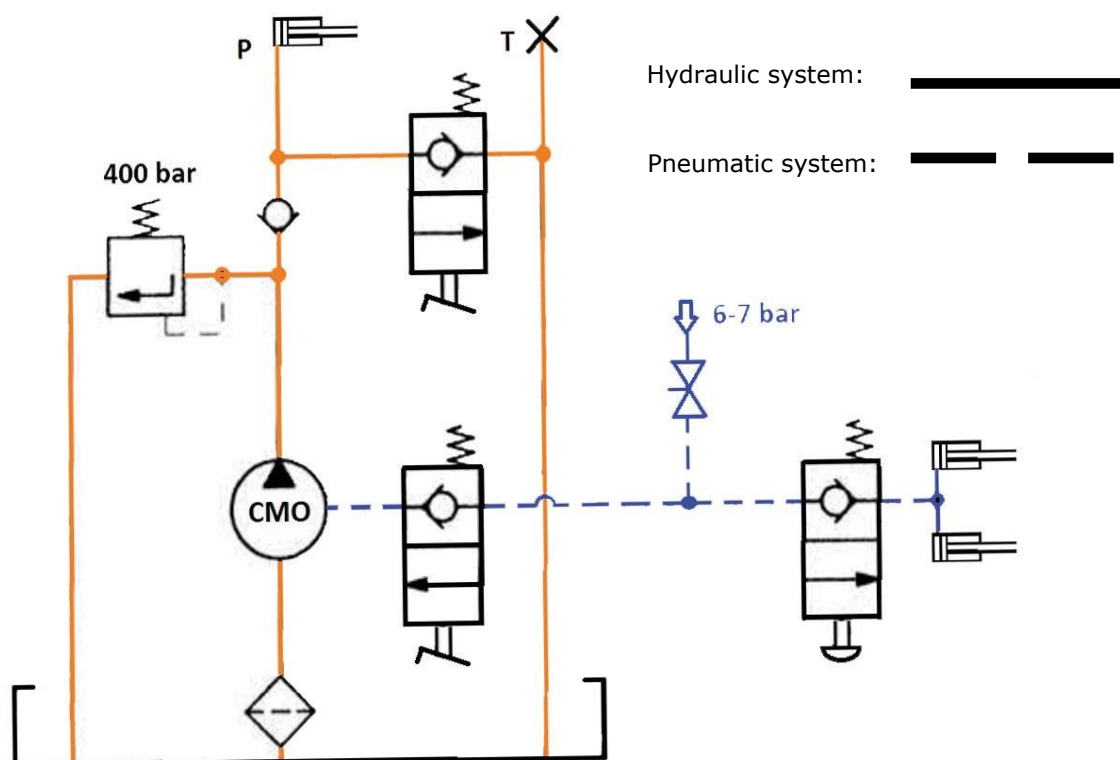


Fig. 31: Hydraulic and pneumatic diagram

## 8.2 Spare parts list

Item no.	Name
HS-3-1	Hydraulic hose 3m, 1 channel
HS-4-1	Hydraulic hose 4m, 1 channel
HS-5-1	Hydraulic hose 5m. 1 channel
HS-3-2	Hydraulic hose 3m, 2 channels
HS-4-2	Hydraulic hose 4m, 2 channels
HS-5-2	Hydraulic hose 5m, 2 channels
EK-2	2-channel hydraulic extender
PZ	Pneumatic actuator
HZ	Hydraulic actuator
HK	Fluid couplings set
HK+	Fluid couplings set, dry closed
PK	Pneumatic coupling
RD	Towing bar
GT125	Rubber plate 125mm
GB20	Rubber block 20x150x120mm
GB40	Rubber block 40x200x110mm
GB50	Rubber block 50x120x120mm
GB72	Rubber block 72x120x120mm
GB100	Rubber block 100x200x120mm
RFW65	Carriage wheels 65mm

Table 4: Spare Parts

## 9. Waste disposal and environmental protection

### NOTE



There is a threat of environmental pollution. Hydraulic oil is hazardous to the environment. A particular hazard exists for drinking water. Leaking hydraulic oil should be removed immediately and disposed of in an environmentally friendly manner.

Dispose of the lift and hydraulic oil in accordance with applicable regulations to avoid environmental hazards.

## 10. List of figures

Fig. 1: Rating plate .....	1
Fig. 2: Recommended load distribution.....	6
Fig. 3: Main components of the lift.....	10
Fig. 4: Supporting component with carrier plate .....	10
Fig. 5: Main components of the foot pedal control unit .....	11
Fig. 6: Unlocking switch.....	11
Fig. 7: Transport rollers.....	13
Fig. 8: Fixing of towing bar .....	13
Fig. 9: Towing bar .....	13
Fig. 10: Hydraulic coupler with transport seal .....	14
Fig. 11: Hydraulic coupler with sealing rings and adapter .....	14
Fig. 12: Installation of the hydraulic coupler .....	14
Fig. 13: Hydraulic coupler installed .....	14
Fig. 14: Compressed air connector with protective cap .....	14
Fig. 15: Compressed air connection.....	15
Fig. 16: Compressed air connection installed .....	15
Fig. 17: Foot pedal controller .....	16
Fig. 18: Hydraulic hose connection .....	16
Fig. 19: Lock release connection hose .....	16
Fig. 20: Compressed air hose connection .....	16
Fig. 21: Oil filler connector with dipstick .....	17
Fig. 22: Measuring dipstick for oil .....	17
Fig. 23: Adjustment possibilities for support arms .....	18
Fig. 24: Unlocking the support arm .....	18
Fig. 25: Layout of holes for adjusting the support arms .....	18
Fig. 26: Support component with support plate on the support arm .....	19
Fig. 27: Setting the support arm and the support component .....	19
Fig. 28: Travel of the lift during upward motion .....	20
Fig. 29: Pin lock with safety cotter .....	21
Fig. 30: Foot pedal .....	22
Fig. 31: Hydraulic and pneumatic diagram .....	25
Fig. 32: General arrangement drawing.....	31

## 11. List of tables

Tab. 1: Maintenance Plan .....	23
Tab. 2: Troubleshooting .....	24
Tab. 3: Technical data .....	25
Table 4: Spare Parts .....	26

## 12. Inspection log with templates

The lift must be inspected at twelve-month intervals by a licensed expert or surveyor using an inspection log. These checks need to be documented.

Experts are distinguished by the fact that they are qualified to inspect and evaluate lifting equipment on the basis of their training and experience. They are also familiar with relevant state health and safety regulations, accident prevention regulations, and generally recognised technical principles.

Surveyors are distinguished by the fact that they have sufficient knowledge and experience with lifting systems to assess the safe condition of a lifting system. They are also familiar with relevant state health and safety regulations, accident prevention regulations, and generally recognised technical principles.

The inspection report must include the following items:

- Date and scope of inspection.
- Identification of any outstanding component inspections, if any.
- The result of the inspection with an indication of the deficiencies found.
- The evaluation of whether there are any concerns regarding commissioning or continued operation.
- Information on additional testing needed.
- Name, address and signature of inspector.

The user must acknowledge in the report that they have reviewed the defects found and that they will be corrected.

Be sure to copy the following forms before regular and extraordinary inspections:

12.5 Regular safety check

12.6 Extraordinary security check

Keep test results in a separate binder.

# 12.1 Inspection review

This lift inspection log no. \_\_\_\_\_ consists of:

- 1. Main page and preview drawing
- 2. Report of the test conducted prior to initial start-up
- 3. Results of regular and extraordinary inspections

Type of test	Date	Sheet no.

The completeness of the inspection log is verified by each expert and surveyor. In all cases, the inspection log should be completed accordingly. Do not remove any cards/pages.

## 12.2 Main sheet

Lift manufacturer/supplier:	Atlas Automotive Equipment
Designation / Type:	
Year of manufacture:	
Serial Number:	
Delivery / start-up date:	
Allowable operating pressure:	max. 7 bar
Lift capacity:	7,000 lbs.
Allowable load distribution:	2:3 / 3:2
Dead weight:	approx. 300 kg
Standing under the load restraints is allowed:	No
Climbing on the load restraints is allowed:	No
Carriage of persons on the load restraints is permitted:	No
Use as a raised work platform is permitted:	No
Maximum lifting speed:	1/4"/s
Maximum lowering speed:	5/8"/s
Safety device against accidental start-up::	Dead man's switch
Safety device against accidental lowering:	Safety bars with safety catches



# 12.3 General arrangement drawing

1020/1070/1150

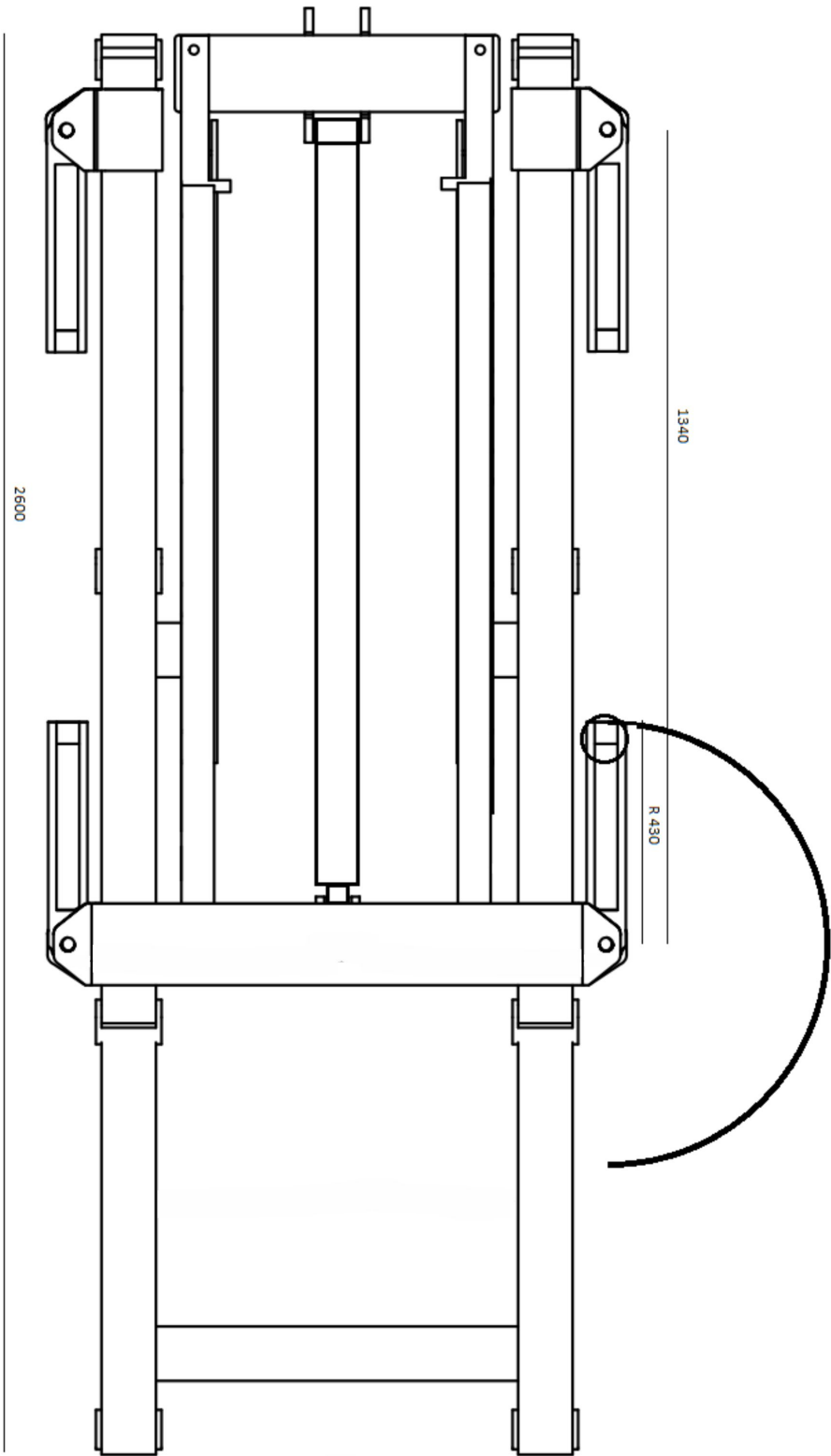


Fig. 32: General arrangement drawing

## 12.4 First start-up

Lift No.: \_\_\_\_\_

Sheet no.: \_\_\_\_\_

	OK	Defective	Additional check	Notes
General condition				
Rating plate				
Warning sign				
User's manual				
Supporting arms condition				
Supporting plates condition				
Hydraulic hoses condition				
Pneumatic hoses condition				
Drive unit condition				
Load-bearing parts condition				
Welds condition				
Paint condition				
Piston rod condition				
Locking pins condition				
Bearings condition				
Hydraulic oil level				
Control unit condition				
Lifting function				
Lowering function				
Dead man's switch function				
Functional of safety device				
Performance test under load				

### Test results

- No defects. Starting is possible without reservations.
- Minor defects. Starting possible. Deadline for defects removal:
- Major Defects. Starting prohibited.

Date	Expert	Address	Signature
Date	User	Address	Signature

Notes

Results of an inspection prior to initial start-up:

Lift no.: \_\_\_\_\_ The sheet no.: \_\_\_\_\_

underwent operability test on ..... The following defects/no defects have been stated\*:

\_\_\_\_\_  
\_\_\_\_\_  
\_\_\_\_\_  
\_\_\_\_\_

Outstanding components tests:

\_\_\_\_\_

The following objections/no objections to commissioning have been stated.\*

Expert

User

\_\_\_\_\_  
Place, date, signature

\_\_\_\_\_  
Signature

Name of expert:  
(in capital letters)

\_\_\_\_\_

Address:

\_\_\_\_\_

\_\_\_\_\_

Occupation:

\_\_\_\_\_

employed in:

\_\_\_\_\_

\* Delete as appropriate.

Notes

## 12.5 Regular safety check

Lift No.:

Sheet no.: \_\_\_\_\_

	OK	Defective	Additional check	Notes
General condition				
Rating plate				
Warning sign				
User's manual				
Supporting arms condition				
Supporting plates condition				
Hydraulic hoses condition				
Pneumatic hoses condition				
Drive unit condition				
Load-bearing parts condition				
Welds condition				
Paint condition				
Piston rod condition				
Locking pins condition				
Bearings condition				
Hydraulic oil level				
Control unit condition				
Lifting function				
Lowering function				
Dead man's switch function				
Functional of safety device				
Performance test under load				

### Test results

- No defects. Starting is possible without reservations.
- Minor defects. Starting possible. Deadline for defects removal:
- Major Defects. Starting prohibited.

Date	Expert	Address	Signature
Date	User	Address	Signature

Notes

Results of the additional inspection:

Lift No.: \_\_\_\_\_

Sheet no.: \_\_\_\_\_

The lift underwent regular operability test on \_\_\_\_\_ The following defects/no defects have been stated\*:

\_\_\_\_\_  
\_\_\_\_\_  
\_\_\_\_\_  
\_\_\_\_\_

Outstanding components tests:

\_\_\_\_\_

The following objections/no objections to commissioning have been stated.\* Expert User

\_\_\_\_\_  
Place, date

\_\_\_\_\_  
Signature

Name of expert: (in capital letters)

\_\_\_\_\_

Address:

\_\_\_\_\_

\_\_\_\_\_

Occupation:

\_\_\_\_\_

employed in:

\_\_\_\_\_

\* Delete as appropriate.

Notes

## 12.6 Extraordinary security check

Lift No.: \_\_\_\_\_

Sheet no.: \_\_\_\_\_

	OK	Defective	Additional check	Notes
General condition				
Rating plate				
Warning sign				
User's manual				
Supporting arms condition				
Supporting plates condition				
Hydraulic hoses condition				
Pneumatic hoses condition				
Drive unit condition				
Load-bearing parts condition				
Welds condition				
Paint condition				
Piston rod condition				
Locking pins condition				
Bearings condition				
Hydraulic oil level				
Control unit condition				
Lifting function				
Lowering function				
Dead man's switch function				
Functional of safety device				
Performance test under load				

### Test results

- No defects. Starting is possible without reservations.
- Minor defects. Starting possible. Deadline for defects removal:
- Major Defects. Starting prohibited.

Date	Expert	Address	Signature
Date	User	Address	Signature

Notes

Results of the extraordinary inspection:

The lift no.: \_\_\_\_\_ The sheet no.: \_\_\_\_\_  
underwent extraordinary operability test on ..... The  
following defects/no defects have been stated\*:

\_\_\_\_\_  
\_\_\_\_\_  
\_\_\_\_\_

Outstanding components tests:

\_\_\_\_\_

The following objections/no objections to commissioning have been stated.\*

Expert

User

\_\_\_\_\_  
Place, date

\_\_\_\_\_  
Signature

Name of expert: (in  
capital letters)

\_\_\_\_\_

Address:

\_\_\_\_\_

\_\_\_\_\_

Occupation:

\_\_\_\_\_













employed in:

\_\_\_\_\_

\* Delete as appropriate.

Notes

## ACCESSORIES

	PART NUMBER	DESCRIPTION
	PM-SLR	Mobile System Wheel - Set of 4 (load 800 kg. each caster)
	PM-PLRA	Plastic Ramps H. 50 mm, plate side 50x50 cm. Kit contains 16 plates +2 wedges. Max. Load 9 t/m2
	PM-E-110V-2	2 way Electric Pump to convert a 1 way to then be able to add the Hydraulic Kit
	PM-2W-HY-A	2 -WAY HYDRAULIK KIT FOR HYDOPNEUM. PUMP
	PM-2W-HY-E	2 Way Hydraulic Kit for Electric Pump (required for mobile and/or loading system)
	PM-FOL20	Foil Rack
	PM-OPAL	Heat Gun Stand
	PM-AR	Steel Ramps - Ideal for Tire Service
	PM-RS-040	Wheel Stands
	PM-RS-060	Wheel Stands
	PM-RS-080	Wheel Stands
	PM-VERL	Loading System



## WARRANTY



This item is warranted for one (2) year on structural components and one (2) year on air or electric hydraulic power units, pneumatic power units, cylinders, and major components from the date of invoice. Wear items are covered by a 90-day warranty.

This **LIMITED** warranty policy does not include a labor warranty.

**NOTE:** All warranty claims must be pre-approved by the manufacturer to be valid.

The manufacturer shall repair or replace, at their option, for this period, those parts returned to the factory freight prepaid, which prove after inspection to be defective.

This warranty will not apply unless the product is installed, used, and maintained in accordance with the manufacturer's installation, operation, and maintenance instructions.

This warranty applies to the **original** purchaser only, and is non-transferable. The warranty covers the product to be free of defects in material and workmanship but does not cover normal maintenance or adjustments, damage, or malfunction caused by improper handling, installation, abuse, misuse, negligence, carelessness of operation, or normal wear and tear. In addition, this warranty does not cover equipment when repairs or alterations have been made or attempted on the manufacturer's products.

**THIS WARRANTY IS EXCLUSIVE AND IS IN LIEU OF ALL OTHER WARRANTIES EXPRESSED OR IMPLIED INCLUDING ANY IMPLIED WARRANTY OF MERCHANTABILITY OR ANY IMPLIED WARRANTY OF FITNESS FOR A PARTICULAR PURPOSE, AND ALL SUCH IMPLIED WARRANTIES ARE EXPRESSLY EXCLUDED.**

The remedies described are exclusive, and in no event shall the manufacturer, nor any sales agent or other company affiliated with it or them, be liable for special, consequential, or incidental damages for the breach of or delay in the performance of this warranty. This includes, but is not limited to, loss of profit, rental or substitute equipment, or other commercial loss.

Prices: Prices and specifications are subject to change without notice. All orders will be invoiced at prices prevailing at the time of shipment. Prices do not include any local, state, or federal taxes.

Returns: Products may not be returned without prior written approval from the manufacturer.

Due to the competitiveness of the selling price of these lifts, this warranty policy will be strictly administered and adhered to.



# **ATLAS**

**Automotive Equipment**

[www.atlasautoequipment.ca](http://www.atlasautoequipment.ca)  
[customercare@atlasautoequipment.ca](mailto:customercare@atlasautoequipment.ca)  
Tel: 866-284-8604

