



**HIGH PERFORMANCE
DIGITAL ELECTRONIC 2-D
WHEEL-BALANCER WITH
VIDEO DISPLAY, LASER LINE
AND LED LIGHT.**

PWB90XL



Ed. 01/19 Cod. 3045153

Use and maintenance instructions
Original Instructions

GENERAL INDEX

Introduction	6
1.0 Foreword	7
1.1 General	7
1.2 Purpose of the manual	7
1.3 Where and how to keep the manual	8
1.4 Manual upgrades	8
1.5 Collaboration with users	8
1.6 Manufacturer's responsibility and warranty	8
1.6.1 Terms of warranty	9
1.7 Technical assistance service	9
1.8 Copyright	9
2.0 Safety rules	10
2.1 General notes	10
2.2 Symbols	10
2.3 Definitions of "operator" and "specialised technician"	10
2.4 Personal protection devices (ppd)	11
2.5 Protection devices to wear	11
2.6 General warnings	12
2.7 Emergencies	12
2.7.1 First aid	12
2.7.2 Fire-fighting measures	13
2.7.3 Airborne noise emission	13
2.7.4 Operator working position	13
3.0 Unpacking and positioning	13
3.1 Visual inspection	13
3.2 Checking the machine and equipment supplied	13
3.3 Unpacking	14
3.4 Packing list	14
3.5 Storage	14
3.6 Handling	15
3.7 Removing the pallet	15
3.8 Positioning	16
3.8.1 Warnings for positioning	16
4.0 Installation	17
4.1 Cleaning	17
4.2 Ambient characteristics	17
4.3 Fitting the adapters	17
4.4 Electrical connection	18
4.4.1 Safety rules	18
5.0 Residual risks	18
6.0 Machine description	19
6.1 Purpose	19
6.2 Technical specifications	20
6.3 Dimensions	20

7.0 Starting	21
8.0 Control panel and components	23
8.1 Automatic distance and diameter gauge	23
8.2 Sonar device for automatic width measurement (optional)	23
9.0 Use of the wheel balancer	24
9.1 Initial screen	24
9.1.1 Screen-save screen	25
9.2 Presetting of wheel dimensions	26
9.2.1 Automatic standard setting	26
9.2.2 ALU-S wheel automatic presetting	28
9.3 User control	29
9.4 Result of measurement	30
9.4.1 Indication of exact correction weight position	31
9.4.2 Opposite weight function (OPF)	32
9.5 "Split" control	33
9.6 Automatic minimization of static imbalance	34
10.0 Menù	35
10.1 Menu access diagram	35
10.2 Imbalance optimization	36
10.3 Dimensions	37
10.4 Statistics	37
10.5 Calibrations	38
10.5.1 Gauges calibration	38
10.5.1.1 Distance gauge calibration	38
10.5.1.2 Diameter gauge calibration	38
10.5.1.3 Width sonar calibration (optional)	39
10.5.2 Balancing Machine Calibration	41
11.0 Setup	42
11.1 General Settings	42
11.2 System Settings	43
11.3 Calibrations	44
11.4 Service	44
11.5 Shaft Imbalance Reset	45
11.6 Diagnostics	45

12.0 Diagnostics	46
13.0 Maintenance	48
13.1 General	48
13.1.1 Introductory notes	48
13.1.2 Safety rules	48
13.1.3 Replacing fuses	48
14.0 Disposal	49
14.1 Disposing of the balancer	49
14.2 Disposing of electronics components	49
15.0 Spare parts	49
15.1 Identification and ordering method	49
16.0 Attached documentation	49

INTRODUCTION

We thank you for purchasing one product included in our range of wheel-balancers.

The machine is manufactured exploiting the best of quality principles.

To ensure correct operation and long life of the machine, all you need to do is follow these simple instructions, which shall be read and fully understood in every single part.

DETAILS OF THE WHEEL-BALANCERS

Please refer to "Wheel balancer Model" and "Serial Number" data on the Data-Plate to provide our Technical Service Dept. with the necessary details for prompt assistance and spare-parts tracking.

These data are found on adhesive labels applied on the machine. For clarity and convenience, we have inserted FAC-SIMILE in the box below.

DETAILS OF THE MANUFACTURER:

- Consult the Declaration of conformity and the data nameplate (fitted on the machine)

NAMEPLATE DATA

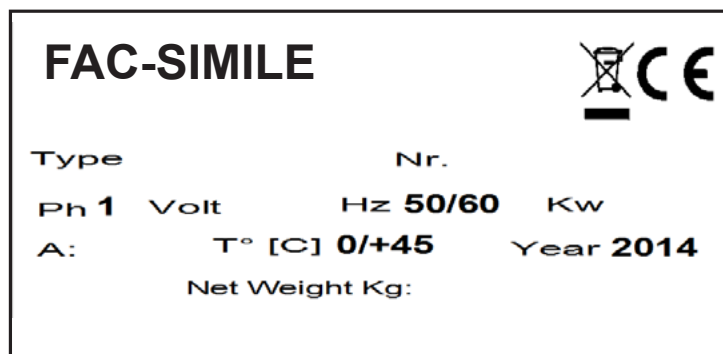

This manual is an integral part of the machine.

Before you use the tyre changer, read the warnings and instructions given in this manual carefully and thoroughly, because they provide important information on safe use and maintenance.



Keep this manual with care for future consultation

NOTE: some of the illustrations shown in this manual have been taken from pictures of prototypes. Consequently, some parts or components of the machines of standard production may differ from what is illustrated.

1.0 FOREWORD



WARNING

This manual is an integral part of the INSTALLATION manual which should be consulted concerning starting and using the machine safely. Read carefully before continuing.

1.1 General

The machine has been constructed in conformity with the current EC Directives and the technical standards implementing the requirements, as stated in the declaration of conformity issued by the manufacturer and attached to the manual.

This publication, hereinafter simply referred to as '**manual**', contains all the information required to safely use and service the machine referred to in the Declaration of Conformity.

This appliance, hereinafter is generically referred to as '**machine**'.

The manual addresses operators instructed on the precautions to take in relation to the presence of electric current and moving devices.

This publication is intended for all 'users' who as far as within their competence need to and/or are obliged to give instructions to others or operate on the machine themselves.

These persons can be identified as follows:

- operators directly involved in transporting, storing, installing, using and servicing the machine from when it is put on the market until when it is scrapped;
- direct private users.

The original Italian text of this publication constitutes the only reference to resolve any interpretation controversies related to the translation into the European Community languages.

This publication forms an integral part of the machine and must therefore be kept for future reference until final dismantling and scrapping of the machine.

1.2 Purpose of the manual

This manual, and the installation manual, contains the instructions required to use the machine safely and carry out routine maintenance work.

Any calibrations, adjustments and extraordinary maintenance operations are not considered in this document as they may only be performed by the service engineer who must work on the machine according to the technical and rated characteristics for which it was built.

Though it is fundamental to read this manual, it cannot replace skilled technical staff who must be adequately trained beforehand.

The foreseen use and configurations of the machine are the only ones allowed by the manufacturer; do not attempt to use the machine in a different way.

Any other use or configuration must be agreed in advance with the manufacturer in writing and in this case an annex will be attached to this manual.

For use, the user must also comply with the specific workplace legislation in force in the country where the machine is installed.

The manual also refers to laws, directives, etc., that the user must know and consult in order to accomplish the goals that the manual sets out to achieve.

1.3 Where and how to keep the manual

This manual (and relative attachments) must be kept in a safe and dry place and must always be available for consultation.

Make a copy and keep it in the archive.

When exchanging information with the manufacturer or the technical assistance staff authorised by the former, quote the rating plate information and the serial number of the machine.

This manual must be kept for the entire lifetime of the machine, and if necessary (e.g.: damage making all or some of it illegible, etc.) the user must request another copy exclusively from the manufacturer, quoting the publication code indicated on the cover.

1.4 Manual upgrades

This manual is an integral part of the machine and reflects the state of the art at the moment it was put on the market. The publication complies with the directives in force on that date; the manual cannot be considered inadequate as a result of regulatory updates or modifications to the machine.

Any manual upgrades that the manufacturer may see fit to send to users will become an integral part of the manual and must be kept together with it.

1.5 Collaboration with users

The manufacturer will be pleased to provide its customers with any further information they may require and will consider proposals for improving this manual in order to more fully satisfy the requirements it was written for.

In case of transfer of ownership of the machine, which must always be accompanied by the use and maintenance manual, the original user must inform the manufacturer of the name and address of the new user in order to allow it to send the new user any communications and/or updates deemed to be indispensable.

This publication is the property of the Manufacturer and may not be fully or partly reproduced without prior written agreement.

1.6 Manufacturer's responsibility and warranty

In order to make use of the manufacturer's warranty, the user must scrupulously observe the precautions contained in the manual, in particular he must:

- never exceed the limits of use of the machine;
- always constantly and carefully clean and service the machine;
- have the machine used by people of proven capacity and attitude, adequately trained for the purpose.

The manufacturer declines all direct and indirect liability caused by:

- use of the machine in a different way from that indicated in this manual
- use of the machine by people who have not read and fully understood the contents of this manual;
- use in breach of specific regulations in force in the country of installation;
- modifications made to the machine, software and operating logic, unless authorised by the manufacturer in writing;
- unauthorised repairs;
- exceptional events.

Transfer of the machine to a third party must also include this manual; failure to include the manual automatically invalidates all the rights of the purchaser, including the terms of warranty, where applicable.

If the machine is transferred to a third party in a country with a different language from the one written in this manual, the original user shall provide a faithful translation of this manual in the language of country in which the machine will operate.

1.6.1 Terms of warranty

If a Manufacturer's repairman (or a person authorised by the same) is required to work at the user's facilities, the relative travel expenses and board and lodging shall be charged to the user.

The free supply of parts under warranty is always subject to the faulty part being inspected by the manufacturer (or a person authorised by the same).

The warranty is not extended following repairs or other work done to the machine.

The warranty does not cover damage to the machine deriving from:

- transport;
- neglect;
- improper use and/or use not in compliance with the instructions in the operating manual
- incorrect electrical connections.

The warranty is invalidated in case of:

- repairs made by people who were not authorised by the manufacturer;
- modifications that were not authorised by the manufacturer;
- use of parts and/or equipment that were not supplied or approved by the manufacturer;
- removal or alteration of the machine identification plate.

1.7 Technical assistance service

For any technical service operation, contact the manufacturer directly or an authorised dealer always quoting the model, the version and the serial number of the machine.

1.8 Copyright

The information contained in this manual may not be disclosed to third parties. Partial or total duplication, unless authorised by the Manufacturer in writing, through photocopying, duplication or other systems, including electronic acquisition, is breach of copyright and can lead to prosecution.

2.0 SAFETY RULES

2.1 General notes



WARNING

Before performing any operation on the machine, carefully read through the entire manual, paying particular attention to this chapter.

The machine has been designed and constructed in observance of the CE requirements taking into account normal and reasonably foreseeable use.

The machine has been constructed for the application stated in the user manual attached hereto.

It is not permitted for any reason whatsoever to use the machine for purposes different from those for which it was designed nor to use it in ways different from those described in this manual.

The various operations must be performed according to the criterion and the chronology described in this manual.

2.2 Symbols

Throughout this manual dangerous operations are highlighted with graphic symbols to draw the reader's attention.



WARNING

This warning indicates possible occurrence of an event that may lead to serious injury or extensive damage to the machine if adequate precautionary countermeasures are not taken.

2.3 Definitions of “operator” and “specialised technician”

Any professional person who is to access the machine for operation and routine maintenance is defined as an “operator”.

This means persons who have knowledge of the operating and maintenance procedures of the machine and have the following qualifications:

1. training that authorises operation according to the safety standards in relation to the risks deriving from the presence of electrical power and moving devices and the risks related to manual load handling.
2. Trained to use the personal protection devices and basic first aid training.

The employer must assign a suitable person to operate the machine in accordance with the laws in force, assessing his or her psycho-physical health, personal education, training and experience, as well as knowledge of the standards, requirements and provisions for accident prevention.

In addition, the operator assigned based on the above must be specifically trained for use of the machine and any accessories.

Finally, the operator must read through this manual.

2.4 Personal protection devices (ppd)



WARNING

During machine installation and use it is strictly prohibited to operate without the protection devices described in this paragraph.

The persons that are to operate on and/or work in proximity of the machine may not wear clothes with wide sleeves, laces, belts, bracelets or anything else that may pose a potential risk. Long hair must be tied up to prevent any risk.

2.5 Protection devices to wear

The following protection devices must be worn.



Insulated safety shoes with rubber sole and reinforced tip

Use: always (EN345)



Protective gloves

Use: always (EN388)



Goggles

Use: always (EN166 1F)



Working clothes

Use: always

2.6 General warnings



CAUTION:

The machine generates, uses and may irradiate energy and radio frequency. If not installed and used in accordance with the instructions in this manual, it may cause interference with radio communications.

- The machine must be installed, maintained and used according to the instructions given in this manual and according to the procedures given from case to case.
- The employer must train the operators for safe installation, use and maintenance of the machine.
- Only specialised and specifically trained persons are to be allowed access to the machine for any extraordinary maintenance operation.
- Before operating on the electrical parts of the machine cut the power.
- For the duration of maintenance, "Work in progress" signs must be posted in the department in such a way that they are visible from all the access areas.
- Always operate with due caution and wear the personal protection devices (PPD).
- The machine (and any accessory devices) must always be connected to earth to discharge short-circuit currents and electrostatic voltages. The mains voltage must correspond to the value shown on the machine identification plate. It is inadvisable to use cable extensions/socket adaptors. When the machine is not used, disconnect it from the mains by pulling the plug from the socket.
- Before carrying out any operation stop the machine.
- In the event of fire, do not use water but only powder or carbon dioxide fire extinguishers.
- It is strictly prohibited to deposit combustible material in the vicinity of the machine.
- Do not deactivate the safety devices or ignore warnings and alarms, be they communicated by the software or by warning labels fixed on the installation. Should the plates, adhesive labels, decals or any other warning sign on the machine deteriorate they must be replaced.
- It is not permitted for any reason whatsoever to modify, tamper with or alter the machine structure, the devices fitted, the operating sequence, etc. without prior consultation with the manufacturer.
- All the routine and extraordinary maintenance operations must be recorded in the logbook noting down the date, time, type of operation, name of the operator and any other useful information.
- In the event of faults or malfunctioning, contact your local distributor or the manufacturer. All the repair operations must be performed by qualified technicians.
- It is strictly prohibited to clean the internal and external electrical parts of the wheel balancer with water.
- Exclusively use alcohol to clean the machine. Do not use any other chemical product. Do not under any circumstances blast with compressed air.
- Do not leave the machine exposed to the rain or the elements. The ambient storage and operating conditions must meet the requirements set out in the chapter INSTALLATION.
- In the event of failure, deformation or malfunctioning of the safety devices, immediately replace them; "Makeshift" repairs are strictly prohibited. Use only original spare parts for which the machine has been designed and constructed.
- The machine and the workplace must be kept perfectly clean.
- When the maintenance operations have been completed, before restoring the power supply, carefully check that you have not forgotten tools and/or other materials in the machine operating area. In any event, also during operation, no object may be placed on the protection shield.

2.7 Emergencies

2.7.1 First aid

For any first aid follow the corporate regulations and conventional procedures.

2.7.2 Fire-fighting measures

Do not use water to extinguish fires, but only powder or carbon dioxide extinguishers. Preferably use extinguishers filled with a special powder for metal fires.

2.7.3 Airborne noise emission

The machine noise, measured with the machine empty, is constantly contained at levels below 70 dB(A). During operation the machine noise is subordinate to the background noise in the workplace, the presence of other machines and other factors that cannot be assessed by the manufacturer in advance. The user therefore needs to make a phonometric measurement of the noise emitted by the machine during normal operation, and provide for personal protection devices (headsets) if the noise emission exceeds the threshold laid down in the regulations in force in the country where the machine is used.

2.7.4 Operator working position

During balancing the operator must stand in front of the control console and avoid standing in front of the wheel during the balancing cycle.

3.0 UNPACKING AND POSITIONING

3.1 Visual inspection

The packaging must be intact upon receipt, i.e.:

- There must not be any sign of collision or breakage
- There must not be any sign that it was exposed to sources of heat, ice, water, etc.
- There must not be any sign of tampering.

Any deformations indicate that the machine was knocked about during transport and may compromise proper machine functioning.

3.2 Checking the machine and equipment supplied

The main body of the machine, the relative accessories and the equipment supplied (as agreed with the manufacturer) must be in perfect condition. The supply is carefully checked before shipment, nevertheless it is advisable to check upon receipt that it is complete and in order.

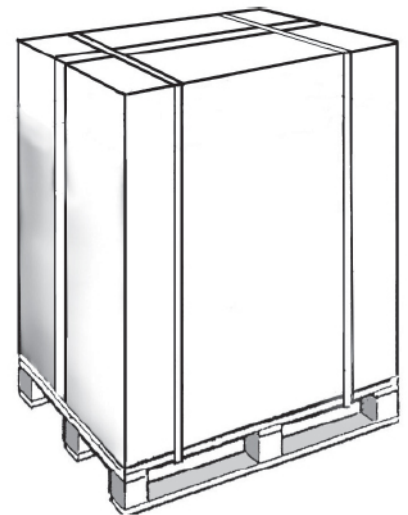

Check that:

- The shipping data (addressee, number of packages, order number, etc.) correspond to the accompanying documentation.
- The technical-legal documentation provided with the machine includes the instruction manual for the type of machine to be installed as well as the EC declaration of conformity or, alternatively, the declaration of the manufacturer.



INFORMATION

In the event of defects and/or missing material immediately notify the manufacturer and follow his instructions before proceeding with installation and startup.

3.3 Unpacking

Operate as follows to unpack the machine:

1. Cut the plastic safety straps
2. Open the top of the cardboard box
3. Remove the top protection
4. Remove any protective corner pieces
5. Remove the cardboard box pulling it upward
6. Remove any protective "pluriball"
7. Inspect the machine to check for any damage. Immediately inform the carrier and the supplier in the event of apparent damage.

Keep the packaging materials for possible future shipment of the machine.



INFORMATION

The packaging used is in compliance with the environmental requirements set out in the European packaging regulations (Official EC Gazette, N. L. 365/19). The cardboard boxes can easily be recycled. The plastic wrappings are made of materials free of hazardous metals. It is advisable to contact the competent local authority for their disposal.

3.4 Packing list

All the materials included in the supply are listed on the packing list. The contents may vary from machine to machine depending on the sales agreements, the optional parts supplied, etc.

Generally, the supply includes:

- the machine
- the toolbox
- the instruction manual

3.5 Storage

When the machine:

- is not immediately installed;
- is uninstalled and stored pending moving to another place position it in a covered place protected against direct contact with atmospheric agents and dust.

The permitted ambient values in the storage area are as follows:

- Temperature: +5° to +50°C (41 - 122°F)
- Relative humidity: 30÷80 %.

If taking the machine out of service after a period of use and after performing the necessary maintenance operations, it can be stored for a period of not more than two years, provided that it is stored in a closed dust-free environment without aggressive agents and with the following characteristics:

- Ambient conditions as described above
- Positioned in such a way that it is protected against deformation, crushing, breakage, etc.
- Not subjected to knocks, vibrations, overhanging loads, etc.

3.6 Handling

The term “handling” means unloading the machine from the means of transport and positioning it in the place where it will be used. Upon receipt the customer needs to unload the machine using his own means and store it in a dry and protected place pending installation.

The machine is to be handled while still fastened on the wooden pallet (see next paragraph) by suitably trained persons wearing the personal protection devices.



WARNING

Handle the machine with extreme care, lifting it the minimum necessary and avoiding dangerous oscillation and unbalancing.

Before moving the machine, it must be tied to the lift truck (or transpallet) to prevent it from shifting and turning over.

Before lifting the machine with a lift truck or transpallet, make sure that the forks are properly positioned and protrude from the opposite side by at least 30 cm.

3.7 Removing the pallet

The machine is secured to a base pallet. Prepare an adequate area with level flooring and mark it off before lifting the machine and positioning it on the ground.

To remove the machine from the pallet operate as follows:

- Remove the screws that lock the machine to the pallet

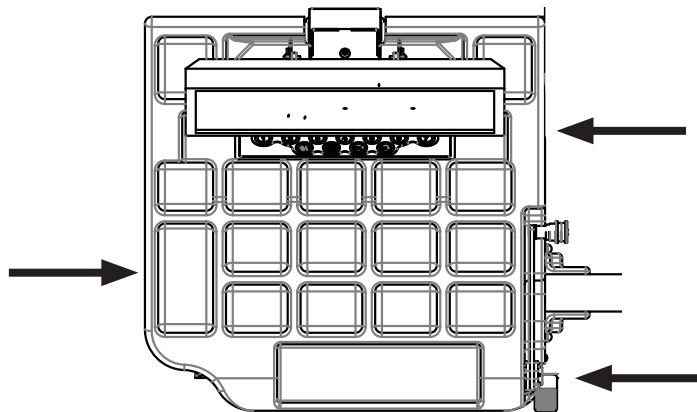

WARNING

Manual handling and lifting of the machine must be carried out with the aid of a lift truck. Prise on the base near the 3 support points as shown in the figure below. Other points, such as the head or the accessory tray, must not be forced under any circumstances.

3.8 Positioning

3.8.1 Warnings for positioning

The machine must be positioned respecting the following conditions:

- The humidity and the temperature must be within the prescribed limits
- The fire-fighting measures must be respected
- Allow for sufficient space at the front, side and rear of the machine for service or periodic maintenance and at the same time to assure adequate air circulation. It is advisable to leave a space of about 1 metre around the machine.
- The place where the machine is installed must be free of corrosive/explosive powders or gas.
- The place of installation must be vibration-free.
- The lighting must be such that the various machine functions can clearly be seen.
- Lift the machine and position it correctly in its final position
- The machine must stand on a flat rigid surface and possibly away from any joint in the floor.

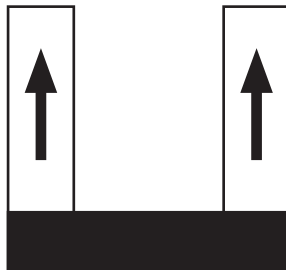
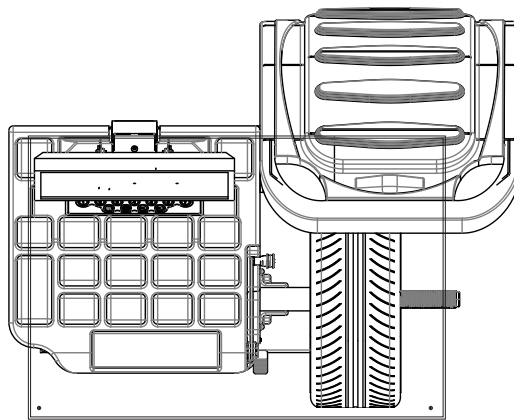

INFORMATION

According to UNI EN 10380 regulations, the lighting for a generic working area (such as control rooms, fixed workstations in production plants, etc.) must on average be 300 lux (acceptable values between 200 and 500 lux). If the machine is installed in a country different from Italy, the specific regulations in that country must be followed.

The lighting system must be such as to guarantee average lighting of 300 lux for the working environment. This value depends on various factors, such as the characteristics of the working environment (more or less reflecting walls and ceiling, height of the light points, etc.) and the type of bulbs used.

4.0 INSTALLATION



WARNING

The instructions in this chapter address the operator who must operate wearing the personal protection devices indicated in chapter 2.5.

4.1 Cleaning

Before starting the machine, clean off any dust, foreign matter and soiling that may have accumulated during transport. Use alcohol to clean the plastic parts.



CAUTION:

Do not use liquids containing solvents or blasts of compressed air to clean the wheel balancer.

4.2 Ambient characteristics

The operating environment must have the following characteristics:

- Temperature: +5° to +50°C (41 - 122°F)
- Maximum relative humidity: 80%

The machine may not be used in open places and/or exposed to atmospheric agents or in environments with corrosive and/or abrasive vapours, fumes or dust with the risk of fire or explosion, and in any case where the use of explosionproof components is prescribed.



CAUTION:

Should at the time of installation the ambient conditions be different from those prescribed, or if they have changed over time, do not use the machine but immediately contact the manufacturer for the relative inspection.

4.3 Fitting the adapters

INFORMATION

Before fitting the terminal to the wheel balancer, it is advisable to thoroughly clean the machine shaft and the adapter hole. Any traces of dirt may affect the balancing accuracy.

The wheel balancer is supplied complete with adapter and cones for fastening wheels with a central hole. The threaded shaft may already be fitted on the machine or be provided in the equipment box; to fit it use an Allen wrench as shown in the drawing. It can be removed to fit optional adapters.

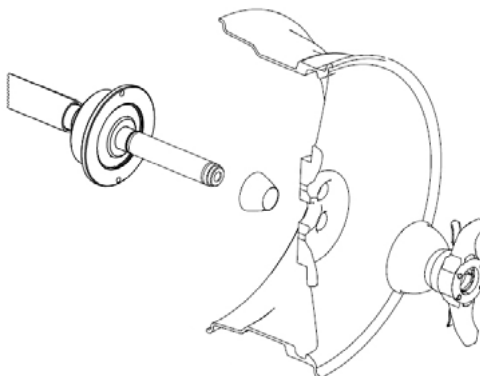

**CAUTION:**

Using non-original accessories might compromise the measuring quality. Contact the manufacturer for the supply of special Adapters or spare parts of any kind.

4.4 Electrical connection

4.4.1 Safety rules

Before performing any operation, read and apply the following:

- Make sure that the main electric cabinet to which the machine is connected is connected to the earth circuit and is adequately protected as required by the regulations in force in the country where the machine is installed. The socket to which the machine is connected must have a slow acting safety switch calibrated to 4 A (230V) or 8A (115V).
- Check that the mains voltage and frequency correspond to the values indicated on the machine identification plate.
- The socket to which the machine is connected must be dimensioned to support the power absorbed up to a maximum of 1.1 kW.

The machine is supplied with a single-phase cable to which a plug conform to the regulations must be connected. If an extension needs to be used, bear in mind that the wire cross-section may not be less than 2.5 mm². Make sure that the extension is arranged so that it does not constitute a risk or obstruction.

**WARNING**

The connection to the single-phase mains must always be made between phase and neutral and never between phase and earth! It is strictly prohibited to turn on the machine if it is not properly connected to earth according to the technical specifications set out in the regulations in force. In any event, the electrical connections must be carried out exclusively by a specialised technician.

5.0 RESIDUAL RISKS

Residual risk means a potential risk impossible to eliminate or partially eliminatable, which may cause injury to the operator if operating using improper working methods and practices.

- Pay attention to the position of your hands in the areas indicated in the figure, as there is a risk of crushing your fingers during wheel locking on the spindle.
- While mounting or dismounting the tyre, pay attention to avoid accidentally crushing your feet.

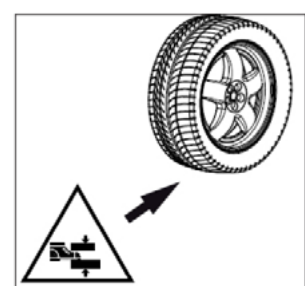
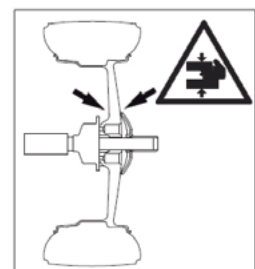

6.0 MACHINE DESCRIPTION

6.1 Purpose

Is used to balance the wheels of cars, vans, 4-WD, motorcycles and scooters weighing less than 75 Kg. It can be operated in the temperature range of +5° to +50°C (41 - 122°F).

The machine can operate only on flat non resilient floor.

To lift the machine, lever only on the base where the 3 support points are located. Never, under any circumstance, apply force to other points such as the spindle, head, or accessory shelf. It functions properly without having to fasten it to the floor with wheels weighing up to 35 kg; for heavier wheels, fasten it at the points indicated. Do not mount anything other than motorbike, car or light truck tyres on the wheel balancer.

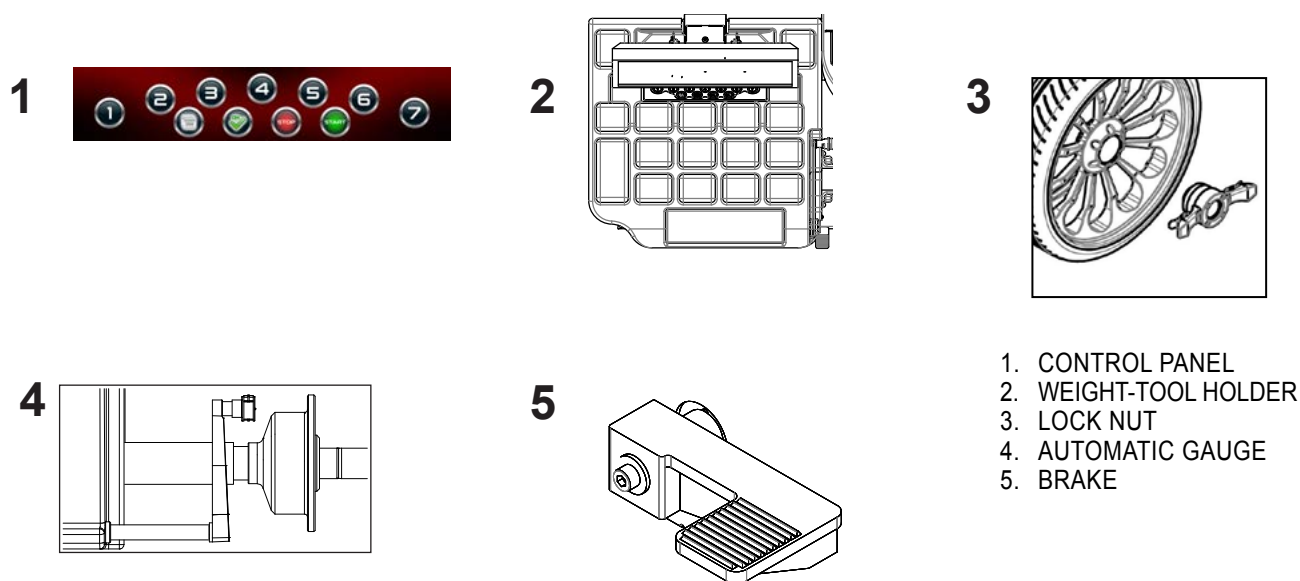

- 1. CONTROL PANEL
- 2. WEIGHT-TOOL HOLDER
- 3. LOCK NUT
- 4. AUTOMATIC GAUGE
- 5. BRAKE

The main features include:

- machine settings menu
- grams/ounces direct selection
- optimisation of tyre and rim imbalance
- static programme, ALU; SPLIT; double operator; self diagnostics; calibration.
- automatic minimisation of static imbalance

6.2 Technical specifications

The following data refers to the balancer in its standard configuration.

Single-phase power supply	230 V 50/60 Hz
Protection class	IP 54
Max.power consumption	0,65 kw
Balancing speed	< 150 rpm
Cycle time for wheel	4.7 sec. (5 3/4"x14") 15 kg.
Measurement uncertainty	0,5 g
Average noise	< 70 dB (A)
Rim width setting range	1.5" ÷ 20" or 40 ÷ 510 mm
Diameter setting range	10" ÷ 30" or 255 ÷ 765 mm
Maximum wheel weight	≤ 75 kg
Net weight with guard	90 Kg

6.3 Dimensions (mm)

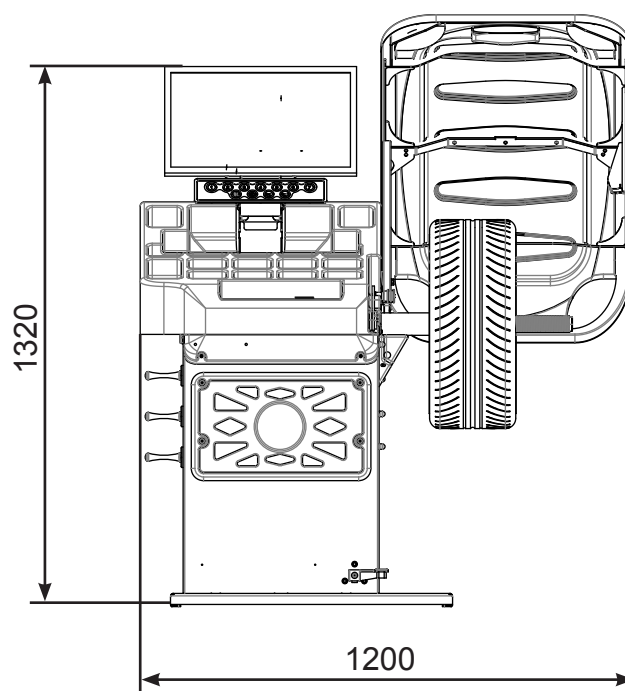
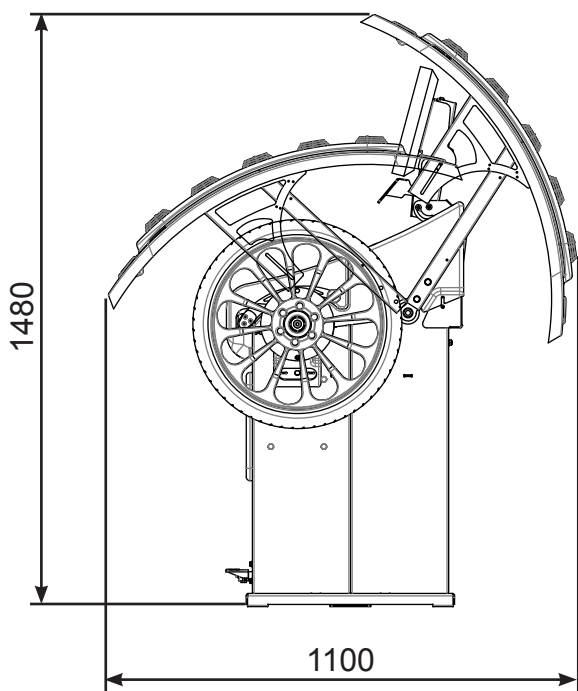

7.0 STARTING



WARNING

Before switching on the machine, make sure that all the connections described in the INSTALLATION chapter have been made correctly. The following operations involve a potential risk for the operator, given the presence of voltage on the equipment. The Personal Protective Equipment described in the INSTALLATION manual must be worn and work must be done with due care and attention. Operations may only be performed by a specialised technician.

Before powering the machine, carry out the following checks:

1. check that the balancing machine touches the floor at the three support points;

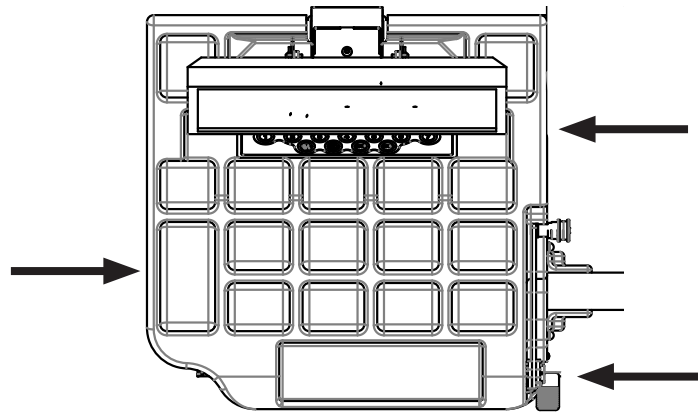

2. make sure that all the parts of the balancer are correctly connected and fixed;
3. make sure that the parameters (voltage and frequency) of the mains power supply are compatible with those indicated on the rating plate of the balancer;
4. make sure the power cable is correctly connected;
5. make sure the machine shaft and flange hole are clean.



CAUTION

Any traces of dirt may affect balancing accuracy.

6. To switch on the balancer press the switch on the left-hand side of the machine.

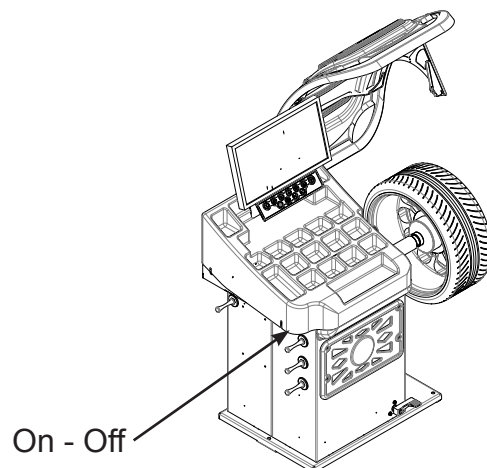

7. Position the wheel on the terminal with the inner part facing the balancer;

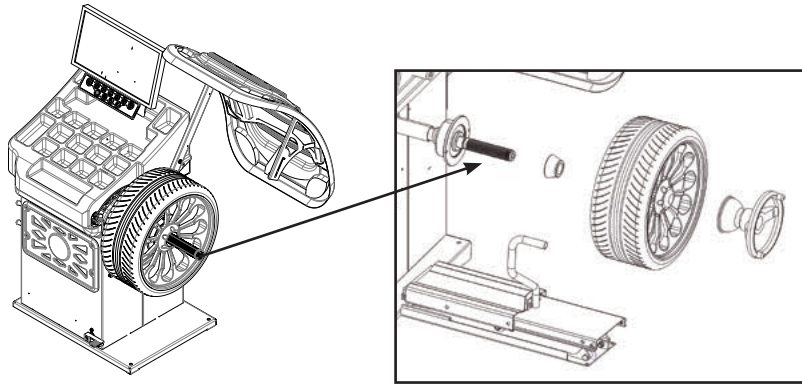

8. Firmly attach the wheel to the balancer shaft using the lock nut.

9. The pedal controls a mechanical brake which facilitates locking the locking ring and positioning the wheel for correction.

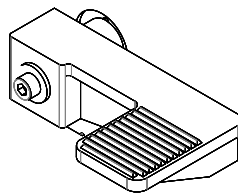

10. At this point, you can read the tyre measurements and perform balancing.

8.0 CONTROL PANEL AND COMPONENTS



CAUTION

Press the buttons with your fingers.

Never use the counterweight grippers or other pointed objects!

The TFT monitor is NOT a TOUCH SCREEN type.

8.1 Automatic distance and diameter gauge

This gauge allows measurement of the distance of the wheel from the machine and the wheel diameter at the point of application of the counterweight. It also allows correct positioning of the counterweights on the inside rim by using the specific function (**INDICATION OF EXACT CORRECTION WEIGHT POSITION**) which allows reading, on the monitor, the position used for the measurement within the rim (for calibration, see the corresponding section).

8.2 SONAR DEVICE for automatic width measurement (option)

Width gauging is through a SONAR device which measures the distance of the wheel without mechanical contact, merely by closing the guard and each time a valid measurement has been made with gauge **AUTOMATIC DISTANCE AND DIAMETER GAUGE**.

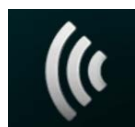

FUNCTION ON
INDICATOR: WIDTH-SONAR.











9.0 USE OF THE WHEEL BALANCER

The monitor shows several information and suggests various alternative ways of use to the operator. This is through various “screens”.

9.1 Initial screen



Buttons enabled:

- | | | | | | |
|---|---|---|--|---|-------------|
|  | 1 USER SELECTION |  | 4 Select the type of weight to apply (CORRECTION METHODS). |  | 7 Next menu |
|  | 2 Display of residual imbalance. |  | 5 Split Program | | |
|  | 3 Dimensions |  | 6 Enable the Adhesive weight applicator (ALU-HELP) | | |
|  | main functions screen (MENU ACCESS DIAGRAM) | | | | |
|  | START WHEEL SPIN | | | | |
|  | STOP WHEEL SPIN / return to initial screen. | | | | |

Dimensions gauge: when extracted, the Dimensions screen is selected (**Presetting of wheel dimensions**). 9.2 If the machine remains on the initial screen for a certain amount of time without being used, the system is automatically switched to a screen-save. Striking of any key, movement of the wheel of distance + diameter gauge will cause automatic switching from the screen-save menu to the initial screen.









CAUTION
when the screensaver is active, automatic starting activated by the guard is not available for safety reasons.

9.1.1 Screen-save screen

Name of the wheel balancer's owner. Can be preset via the monitor.



Icons	Description	Status
	Adhesive weight at 6 o'clock:	Enabled and active
	LED light :	Enabled and active
	LASER line at 6 o'clock:	Enabled and active
	Width-Sonar (LA) :	Enabled and active
	Adhesive weight at 6 o'clock:	Enabled but NOT active For the type of selected program
	LED light at 6 o'clock:	Enabled but NOT active For the type of selected program
	LASER line at 6 o'clock:	Enabled but NOT active For the type of selected program

9.2 Presetting of wheel dimensions

9.2.1 Automatic standard setting

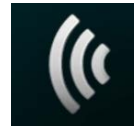

FUNCTION ON
INDICATOR: WIDTH-SONAR.

a) Standard weight

Using the special grip, move the end of the gauge against the rim in one of the positions A/B shown:

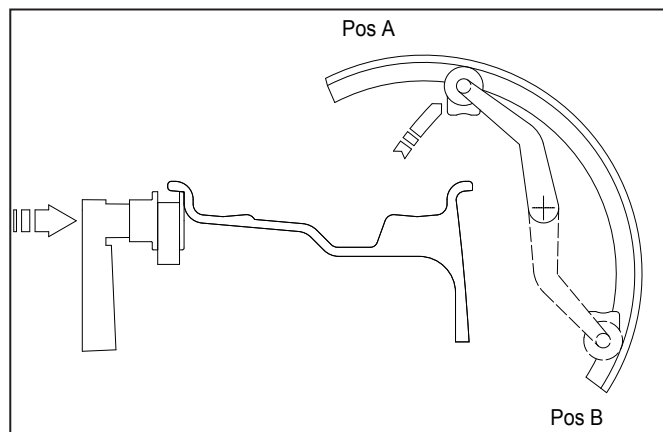

b) **Adhesive weight:** in the position indicated below.

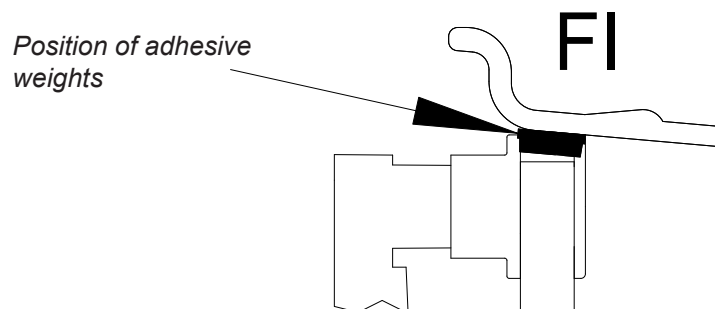



INDICATION

always use the round part of the end of the gauge.

Hold the gauge in position for at least 2 seconds.

If the acoustic signal is enabled (**ACOUSTIC SIGNAL**), the acquisition of the dimensions is accompanied by a “beep”.
Set the distance+diameter gauge to the rest position.



The other enabled buttons are:



USER SELECTION



Select the type of weight to apply (CORRECTION METHODS).



Back to the main screen



Select the dimension to change



Decrease in value of the selected dimension



Return to initial screen.



Disabled



Increase in value of the selected dimension



START WHEEL SPIN



After having detected the dimensions, use the **4** key to indicate the type of correction selected for the inner side.

The buttons enabled in the case of:

- automatic width measurement

- automatic ALU-S wheel measurement

are:



9.2.2 ALU-S wheel automatic presetting

After the measurement performed for the FI inner side, as indicated in the figure, pull out the gauge again to store the data for the FE outer side; choose position A or B at your choice. Keep this position for at least 2 seconds. When the acoustic signal is enabled (**ACOUSTIC SIGNAL**), the acquisition is accompanied by a “beep”.

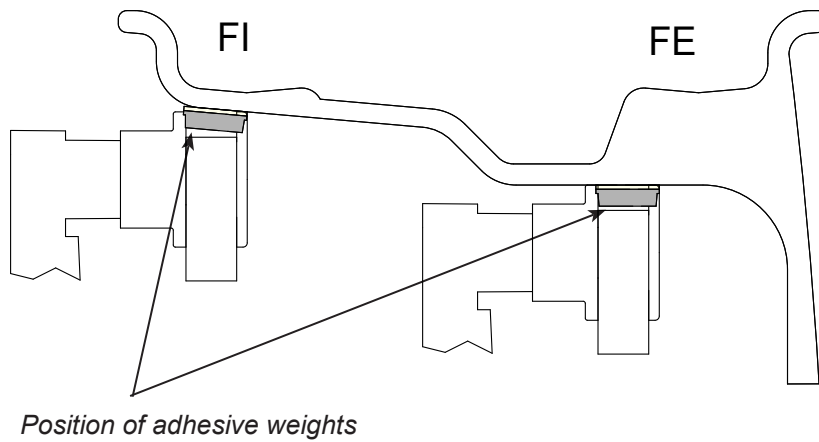

1 USER SELECTION



4 Disabled



7 Back to the main screen



2 Select the dimension to change



5 Decrease in value of the selected dimension



Return to initial screen.



3 Select the type of weight to apply (inner side).



6 Increase in value of the selected dimension



START WHEEL SPIN



INDICATION

The ALU-S dimensions can in any case be set manually using the buttons described in “PRESETTING OF WHEEL DIMENSIONS”.

9.3 USER control

Selected by pressing **WHEEL DIMENSIONS**).



from the automatic setting mode for standard wheels (**PRESETTING**



The wheel balancing machine can be used simultaneously by 5 different users who, through a simple sequence, can memorize their work condition and call it when needed.

1 selecting the user to call up and program

1 2 3 4 5 recalling the selected user

The system automatically returns to the initial screen with recalculation of the imbalance values on the basis of the effective dimensions of the USER called.



INDICATION

*The dimensions memorized as USER are lost when the machine is switched off;
The current USER is always displayed in the Measurements and Dimensions screens.*



INDICATION

Remember to set correctly the dimensions in the manner already described in the paragraph "PRESETTING OF WHEEL DIMENSIONS".

9.4 Result of measurement



- | | | |
|---|---|-------------------------------|
| 1 user selection | 4 selection of weights positioning | 7 Next menu |
| 2 display of residual imbalance. | 5 Split Program | START START WHEEL SPIN |
| 3 Dimensions | 6 Enable the Adhesive weight applicator (ALU-HELP) | |



- 1** Back to the previous menu
- 2** It is possible to select whether to display the imbalance values expressed in grams or ounces.
- 3** Imbalance optimization

After performing a balancing run, the imbalance values are displayed as well as arrows useful for positioning the correction weight at the application point. After positioning and locking the wheel, apply the weight vertically at the top. When the beep signal is enabled (**ACOUSTIC SIGNAL**), reaching of the correction position is accompanied by a “beep”. If the imbalance is less than the chosen threshold value, “OK” appears instead of the imbalance value to indicate, on that particular side, that the wheel is in tolerance; the residual imbalance can be displayed by pressing the button **2**, with an accuracy of 0.5 g (0.1 oz.)



INDICATION

If the machine remains on this screen without being used for more than the time preset in the Setup parameters, the screen automatically returns to the screen-save.

9.4.1 Indication of exact correction weight position

Press



It is recommended to always use this function when correcting the imbalance with adhesive weights. Remember to thoroughly clean the application areas. In all cases this function allows cancelling approximations in adding counterweights with consequent reduction of the residual imbalance. On measurement results screen:

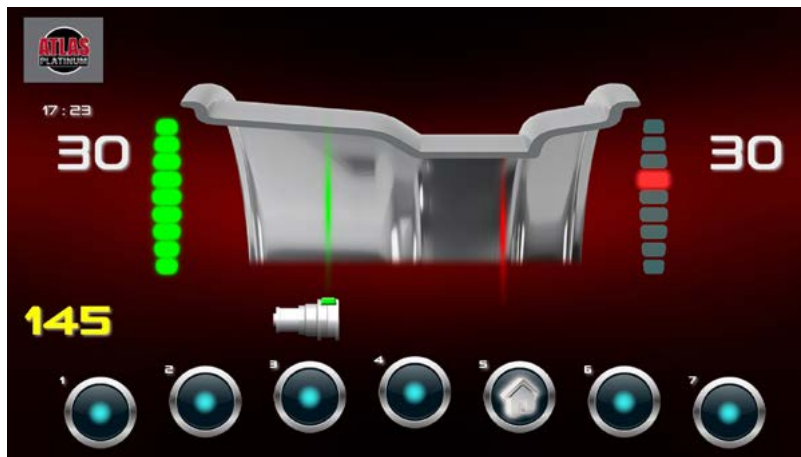

Pull out the gauge until the counterweight applicator reaches the previously selected area, FI or FE.



A mobile RED line indicates that the counterweight is reaching the correction position.



When the correct position for counterweight is reached, the reference line switches to the green color



Hold the gauge in this position and spin the wheel manually until the correct angular position is reached. (all indicator lights become green)



At this point the applicator color switches to green.

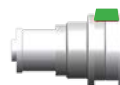

Now, it is possible to apply the counterweight by rotating the gauge outwards. Keep the counterweight centered relative to the position where the applicator touches the inside of the rim.



The correction weight application position is automatically reset in relation to the angular position of the distance + diameter gauge.

When the acoustic signal is enabled (**ACOUSTIC SIGNAL**), attainment of the reference is accompanied by a “beep”.

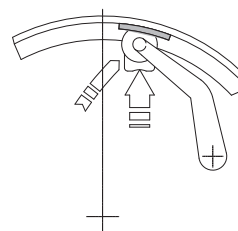
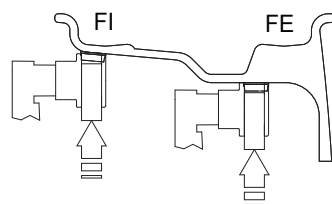

9.4.2 OPPOSITE WEIGHT FUNCTION (OPF) for adhesive weights

The normal balancing condition requires the correction weight to be applied at the top (12 o'clock) when the symbol is displayed:

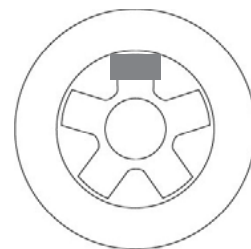

If **OPPOSITE WEIGHT FUNCTION** is enabled, the eventual application position for the bottom weight (6 o'clock) is also indicated next to the positioning arrows to facilitate cleaning the rim and the relative application of adhesive weights. The symbol used is:

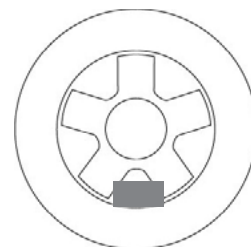
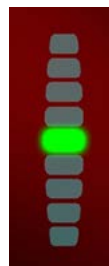

Just before reaching the weight correction position, the LED light comes on. When reaching the exact weight correction position, the LASER activates.



9.5 "SPLIT" control

SPLIT is only possible in the event of static imbalance or ALU-S external side and is used to hide any adhesive weights correcting imbalance behind the rim spokes.



To split the imbalance detected in two different positions, proceed as follows :

1. Position static imbalance or ALU-S external side in the correction position :

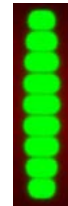

2. Select a spoke close to the 12 o'clock position to be corrected, move it into the 12 o'clock position and press button **5**



3. Spin the wheel in the rotation direction indicated on the imbalance display, bringing the second spoke to the 12 o'clock position and press button **5**.



4. At this point, two indications appear on screen for positioning of the imbalance correction weights behind the selected spokes.

5. Position the spokes indicated on screen in the 12 o'clock position and correct with the value displayed.



Any error in this procedure is clearly shown on screen.

Always follow the information provided by the wheel balancer to optimise correction.

10.0 MENÙ

10.1 Menu access diagram

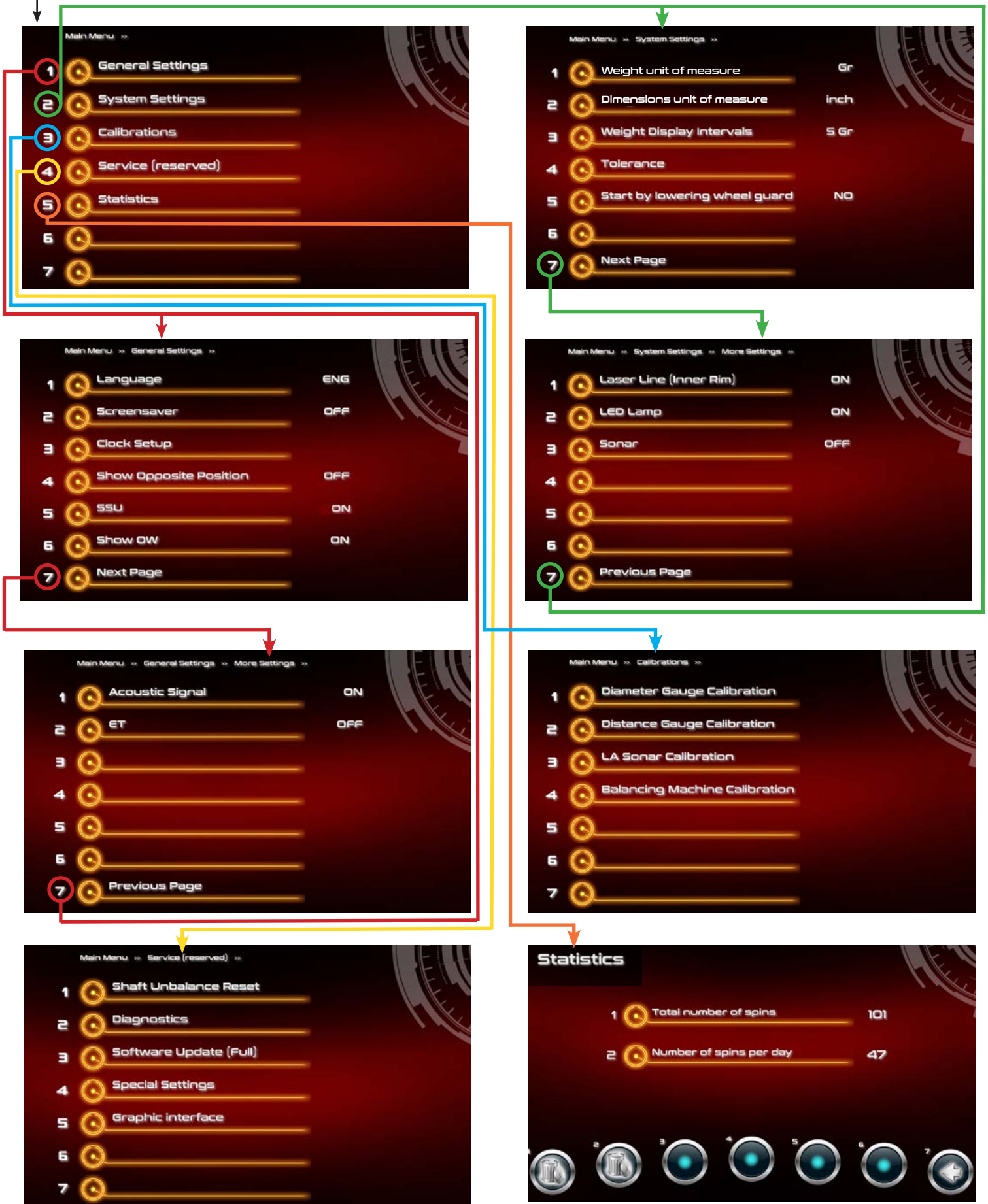

10.2 Imbalance optimization









14 : 30



Make sure the previous spin was made with the same wheel now mounted on the wheel balancer.

Then, follow these steps:

1. Make a reference mark on the hub and rim to allow the rim to be clamped again in the same position on the hub.
2. Remove the wheel from the balancing machine
3. Turn the tyre by 180 degrees on the rim
4. Mount the wheel on the balancer machine, matching the reference mark on the rim with that on the hub
5. Lower wheel guard and press START

If the function is enabled:

The symbol  is displayed automatically for static imbalance exceeding 30 grams (1.1oz). The program allows total wheel imbalance to be reduced by compensating, when possible, tyre and rim imbalance values. It requires two runs, rotating the tyre on the rim on the second run. Having performed a run, press  +  and follow the on-screen instructions.

Initial static imbalance Percentage of reduction of static imbalance obtained by performing optimization procedure.



10.3 Dimensions

Selecting the manual dimension presetting screen.



10.4 Statistics

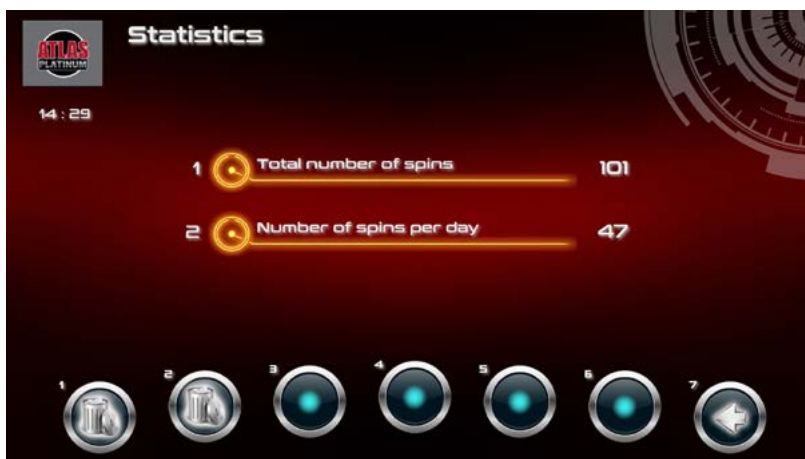

DAILY N° OF RUNS:

Indicates the number of runs performed daily or after the last reset.

TOTAL N° OF RUNS:

Indicates the number of runs starting from the date of installation or since the last reset.

The following buttons are enabled:



Press **1** or **2** to reset the relative counter.

7 Display the previous Menu

10.5 Calibrations

When  is pressed from the Special Functions menu, access is gained to the Calibration menu.

10.5.1 Gauges calibration

10.5.1.1 Distance gauge calibration

To calibrate the distance gauge, set it in rest position and then on the adapter plane. When done, set the gauge in rest position. If calibration is correct, the wheel balancer is ready for operation, otherwise an error message may be displayed if there are errors or malfunctioning; in this case repeat calibration.

 to cancel the distance gauge calibration function if has erroneously been accessed.



10.5.1.2 Diameter gauge calibration

Position the gauge rod of the spindle sleeve as indicated in the figure and press .

Rotate the gauge downwards and place the gauge rod in contact with the spindle sleeve and press .

Enabled buttons:

 confirms

 cancels the diameter gauge calibration function if has erroneously been accessed.



10.5.1.3 Width sonar calibration (optional)

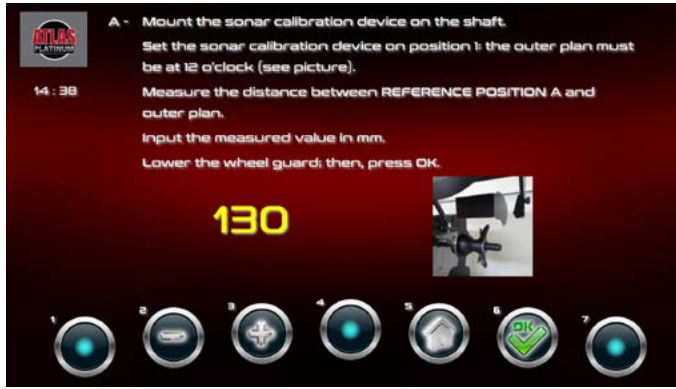

1) Install the calibration device as shown in the picture



Turn the calibration device so that the outer plane, the one closest to the sonar, is at 12 o'clock, positioned in front of the sonar. Measure the distance between the reference line on the sonar protection and the plane of the calibration device opposite to the sonar.

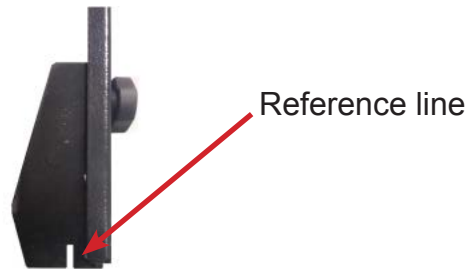

Insert the distance measured in mm using the **2** and **3** keys, changing the displayed value 130 (mm).



Then press the **OK** key to confirm



NOTE: accidental shocks can deform the wheel guard structure and therefore the position of Sonar support. If the measurement taken with RULER is not between 130-135mm, manually carry out adjustment on the wheel guard, by increasing or decreasing the distance, until it is within the required range.

2) Turn the calibration device so that the inner plane, the one furthest from the sonar, is at 12 o'clock, positioned in front of the sonar.

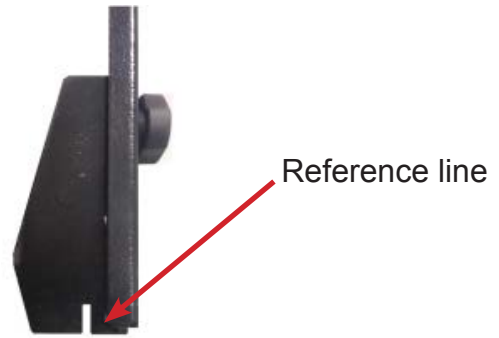

Measure the distance between the reference line on the sonar protection and the plane of the calibration device opposite to the sonar





Insert the distance measured in mm using the  and  keys, changing the displayed value 330 (mm).

Then press the  key to confirm
3) Remove calibration device.

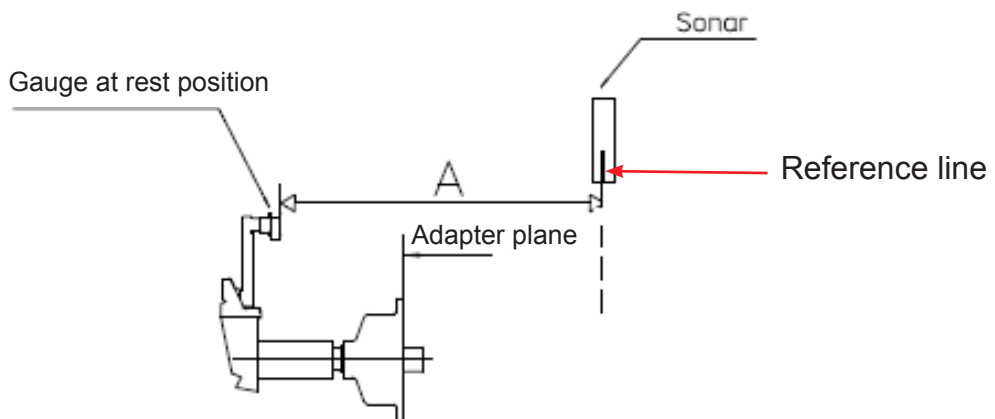

Measure the distance (in mm) between the reference line on the sonar and the distance gauge clip in rest position (ZERO POSITION)



Insert the distance measured in mm using the  and  keys, changing the value displayed on the right display, 550 (mm).

Press the  key to confirm.

Press the  key to confirm.

10.5.2 Balancing machine calibration

To calibrate the balancing machine, use a wheel with steel rim of average dimensions, e.g. 6" x 14" (± 1 ").

To properly perform the procedure:

- Mount a wheel on the machine, even imbalanced, and very carefully set its dimensions.

INDICATION



Setting incorrect measurements will result in the machine not being correctly calibrated, and balancing of subsequent wheels will hence be incorrect until the machine is recalibrated with the correct measurements!!

- Follow the on-screen instructions.

1.



2.



3.



4.



5.



11.0 SETUP

The Setup screen provides the user with many possibilities required for presetting the machine according to his own requirements. Such settings remain unaltered even when the machine is switched off.

The following buttons are enabled:



return to Measurement screen



return to previous screen

from **1** to **5** for selection of the parameter.



11.1 GENERAL SETTINGS



Press the **1** button to enter the General Settings screen where you can select the following items:



1) Language

This function allows selecting the language to be used for displaying descriptive and diagnostic messages regarding machine operation.

2) Screen-saver time

If this function is enabled, the screensaver will automatically be activated when the machine is not used for a certain period of time. This function can be disabled by setting it to 0.

3) Setting the clock

Used to set date and time correctly. Follow the instructions on the screen.

4) Show Opposite Position

When "ON" is selected, this function shows opposite Position (enables to place the weight at 6 o'clock)

5) Enable SSU (via password)

Function not enabled

6) Enable OW function

For static imbalance higher than 30gr.

7) Next page



1) Acoustic signal

When "ON" is selected, the sending of an acoustic signal (beep) is enabled.

2) Enable ET function

When "ON" is selected, this function enables recognition of SUV wheel width

7) Previous page

11.2 SYSTEM SETTINGS

Press the  button to enter the System Settings screen where you can select the following items:

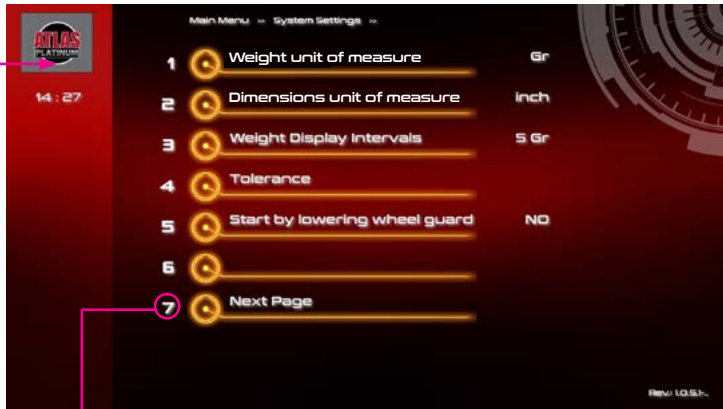

1) Weight unit of measure

It is possible to select whether to display the imbalance values expressed in grams or ounces.

2) Dimensions unit of measure

In inches or mm

3) Weight Display Intervals

This represents the display pitch of the imbalance and varies according to the unit of measurement selected. The selection “5 g” (1/4 oz) enables display of the correction values on both sides such as to bring the static imbalance to 0 (theoretical). It is recommended to preset this function as standard use of the machine as it improves the balancing quality. The computer makes a complex calculation which allows cancelling the residual static imbalance by varying the value and position of the counterweights fixed in steps of 5 grams (1/4 oz).

4) Tolerance

This is the imbalance threshold below which the word “OK” instead of the imbalance value appears on the screen at the end of the spin:

5) Spin with guard closed

When “ON” is selected the automatic start of the spin is enabled when the guard is closed.

7) Next page



1) Laser line

When “ON” is selected the laser line is enabled

2) LED lamp

When “ON” is selected the LED lamp is enabled

3) Sonar

When “ON” is selected the Width-Sonar is enabled

7) Previous page

11.3 CALIBRATIONS

Press the  button to enter the Calibrations screen where you can select the following items:

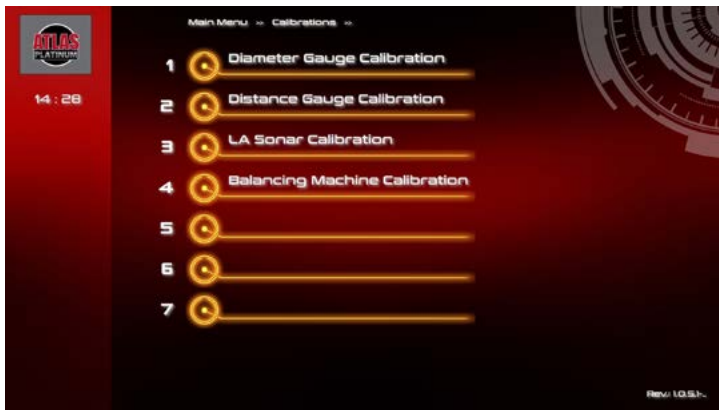

1) Diameter Calibration

Diameter Gauge Calibration

2) Distance Calibration

Distance Gauge Calibration

3) Sonar calibration (optional)

Width-Sonar calibration

4) Balancing Machine Calibration

Balancing Machine Calibration

11.4 SERVICE

Press the  button to enter the Service screen where you can select the following items:



1) Shaft Imbalance Reset

Calibration of the shaft assembly only

2) Diagnostics

Access reserved to authorized technicians (via password), to view machine parameters

3) Software Update (Full)

Function not enabled

4) Special Settings

Function not enabled

5) Graphic interface

Function not enabled

11.5 Shaft Imbalance Reset

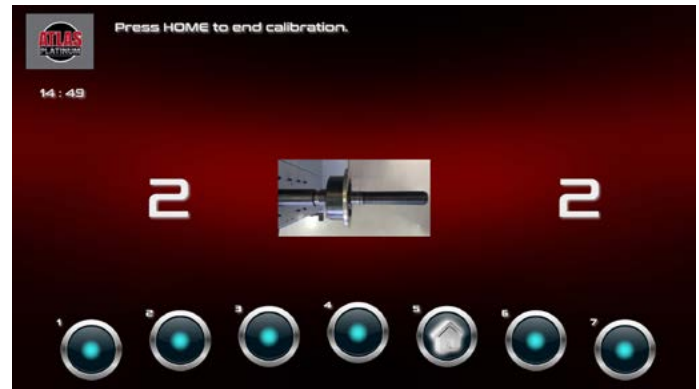

11.6 Diagnostics

PASSWORD : 731642

Main Menu >> Service (reserved) >>

1 Shaft Unbalance Reset

Diagnostics

Balance		Wheel		Status	
Weight Inner	(0, 128)	Diameter	368	I/O	0
Weight Outer	(0, 128)	Distance	95	Logic	StandBy
Weight Static	(0, 120)	Width	158	Motor	ShotDone
Position Inner	135	Diameter Inner (ALU)	300	Show	Dynamic
Position Outer	56	Diameter Outer (ALU)	420	Encoder (ADC)	0
Position Static	24	Distance Inner (ALU)	105	Speed (RPM)	0
Rh	2000	Distance Outer (ALU)	195	Caliber Dist. (mm)	0
Rv	2000			Caliber Dist. (ADC)	0
				Caliber Diam. (°)	0
				Caliber Diam. (ADC)	0
				Sonar (mm)	0
				Sonar (ADC)	0
				Opt.	0

12.0 DIAGNOSTICS



WARNING

The information in the **POSSIBLE REMEDY** column requires work to be performed by specialist technicians or other authorised people who must always work using the Personal Protective Equipment indicated in the **INSTALLATION** manual. In some cases, this work can be performed by a normal operator.

ERROR	CAUSE	POSSIBLE REMEDY
Black	The wheel balancer does not switch on.	<ol style="list-style-type: none"> 1. Verify correct connection to the mains. 2. Verify and eventually replace the fuses on the power card. 3. Verify monitor function. 4. Replace the computer board.
Err. 1	No rotation signal.	<ol style="list-style-type: none"> 1. Check in self-diagnostics that the encoder functions properly. 2. Replace the phase pick-up board. 3. Replace the computer board.
Err. 2	Speed too low during detection. During the imbalance measurement revolutions, the wheel speed has fallen to below 42 rpm.	<ol style="list-style-type: none"> 1. Make sure that a vehicle wheel is mounted on the wheel balancer. 2. Use the self-diagnostics function to check the encoder. 3. Disconnect the piezo connectors from the board and do a spin (if no error is detected, replace the piezo sensors). 4. Replace the CPU board.
Err. 3	Imbalance too high.	<ol style="list-style-type: none"> 1. Verify wheel dimension settings. 2. Check detection unit connections. 3. Perform machine calibration. 4. Mount a wheel with more or less known imbalance (less than 100 grammes) and verify the response of the machine. 5. Replace the computer board.
Err. 4	Rotation in opposite direction. After pressing [START], the wheel starts turning in the opposite direction (anticlockwise).	<ol style="list-style-type: none"> 1. Check in self-diagnostics that the encoder functions properly 2. Check the bearing/spring of the phase generator
Err. 5	Guard open The [START] pushbutton was pressed without first closing the guard.	<ol style="list-style-type: none"> 1. Reset the error by pressing pushbutton [7]=End. 2. Close the guard. 3. Verify the function of the protection uSwitch. 4. Press the [START] pushbutton.
Err. 7 / Err. 8	NOVRAM parameter read error	<ol style="list-style-type: none"> 1. Repeat machine calibration 2. Shut down the machine. 3. Wait for a minimum time of ~ 1 Min. 4. Re-start the machine and verify correct operation. 5. Replace the computer board.
Err. 9	NOVRAM parameter write error.	Replace the computer board.
Err. 11	Speed too high error. During imbalance measurement rotation, wheel speed is more than 270 rpm.	<ol style="list-style-type: none"> 1. Check if there is any damage or dirt on the timing disc. 2. Check in self-diagnostics that the encoder functions properly. 3. Replace the computer board.
Err.13/ Err.14/ Err.15/ Err.16/ Err.17/ Err.18/ Err.19	Imbalance measurement error.	<ol style="list-style-type: none"> 1. Check in self-diagnostics that the encoder functions properly 2. Check detection unit connections. 3. Verify machine earth/ground connection. 4. Mount a wheel with more or less known imbalance (less than 100 grammes) and verify the response of the machine. 5. Replace the computer board.
Err. 22	Maximum number of spins possible for the imbalance measurement has been exceeded.	<ol style="list-style-type: none"> 1. Check that a vehicle wheel has been mounted on the wheel balancer. 2. Check in self-diagnostics that the encoder functions properly 3. Replace the computer board.
Err. 30	Clock error	Replace the computer board.
Err.40/ Err.41/ Err.42/ Err.43	Eccentricity graph plotting procedure error.	Perform a new eccentricity measurement.

Err.45/ Err.46/ Err.47/ Err.48	Eccentricity graph value display readout error.	Perform a new eccentricity measurement.
Err.50/ Err.51/ Err.52/ Err.53	Eccentricity graph current value cursor plotting procedure error.	Perform a new eccentricity measurement.
Err.54	Sonar readout error. Sonar value readout impossible.	<ol style="list-style-type: none"> 1. Position the eccentricity measurement sonar correctly before performing the measurement. 2. Check eccentricity sonar connections. 3. Check the power supplies on the power board. 4. Replace the eccentricity measurement sonar. 5. Make sure that the wheel does not halt before completing at least 4/5 revolutions after the first braking impulse. 6. Replace the computer board.
Err.55	Sonar readout error. Sonar values are insufficient for correct measurement of eccentricity.	<ol style="list-style-type: none"> 1. Position the eccentricity measurement sonar correctly before performing the measurement. 2. Make sure that the wheel does not halt before completing at least 4/5 revolutions after the first braking impulse. 3. Mount a wheel of medium dimensions (14"x5 3/4") and perform an eccentricity measurement . If in these conditions error 55 no longer occurs, this means that the wheel inertia causing the problem is such as to half the wheel before having acquired the minimum number of values necessary for reliable eccentricity measurement.
Err.56	Lateral Sonar readout error. Lateral Sonar value readout impossible.	<ol style="list-style-type: none"> 1. Position the eccentricity measurement lateral sonar correctly before performing the measurement. 2. Check eccentricity lateral sonar connections. 3. Check the power supplies on the power board. 4. Replace the eccentricity lateral sonar. 5. Make sure that the wheel does not stop before completing at least 4/5 revolutions after the first braking impulse. 6. Replace the computer board.
Err.57	Lateral Sonar readout error. Lateral Sonar values are insufficient for correct measurement of lateral eccentricity.	<ol style="list-style-type: none"> 1. Position the eccentricity lateral sonar correctly before performing the measurement. 2. Make sure that the wheel does not stop before completing at least 4/5 revolutions after the first braking impulse. 3. Mount a wheel of medium dimensions (14"x5 3/4") and perform an eccentricity measurement . If in these conditions error 57 no longer occurs, this means that the wheel inertia causing the problem is such as to half the wheel before having acquired the minimum number of values necessary for reliable lateral eccentricity measurement.
Err.58	Radial and lateral Sonar readout error. Radial and lateral Sonar value readout impossible.	<ol style="list-style-type: none"> 1. Check points Err. 54 2. Check points Err. 56
Err.59	Radial and lateral Sonar readout error. Lateral and radial Sonar values are insufficient for correct measurement of radial and lateral eccentricity.	<ol style="list-style-type: none"> 1. Check points Err. 55 2. Check points Err. 57
Err.65	Printer timeout	<ol style="list-style-type: none"> 1. Check that a printer is present. 2. Check the code of the processor card. 3. Check the printer <-> processor card connection. 4. Run the printer test function.
Err.66	Printer buffer error	<ol style="list-style-type: none"> 1. Reset the printer. 2. Repeat the print function.
Imbalance incorrect with back centring cones	Wheel slipping on the adapter because the BP system is at the end of travel or because of incorrect fitting of the tyre tie-rod	Mount the wheel in vertical position and push the sleeve up against the wheel. If necessary, repeat locking/unlocking/locking and perform the procedure again.

13.0 MAINTENANCE

13.1 GENERAL



CAUTION

Before performing any maintenance operations, make sure the machine has been disconnected from the mains power supply. Always use the Personal Protective Equipment indicated in the Installation Manual.

13.1.1 Introductory notes

This machine has been designed so as not to require routine maintenance, apart from accurate periodic cleaning. It is important to keep the machine perfectly clean in order to prevent dust or impurities from compromising the operation of the balancer.



WARNING

The people responsible for cleaning the area where the machine is installed must wear personal protective equipment in order to work in safety and according to the current occupational health and safety regulations.

As extraordinary maintenance must be performed by service staff or, in any case, by specifically authorised and trained people, is not dealt with in this manual.

13.1.2 Safety rules

Performing specialist activities on the equipment, particularly if the guards need to be dismantled, exposes people to serious danger due to the presence of potentially live parts.

The rules shown below must be scrupulously followed.

People must always use the Personal Protective Equipment indicated in the Installation Manual. During activities, unauthorised people may not access the equipment and WORK IN PROGRESS signs will be erected in the department in such a way that they are visible from every place of access.

Specialist staff must be authorised and especially trained concerning the dangers that may arise during operation and the correct methods for avoiding them.

They must always work with great care and pay full attention.

If, exceptionally, the staff removes the guards to carry out a particular specialist technical maintenance, inspection or repair job, they are required to put them back after work.

After work, staff must make sure that foreign objects, in particular mechanical pieces, tools or devices used during the operative procedure that could cause damage or malfunctions are not left inside the balancer.

For safety, before starting work, maintenance, inspection and repair staff must disconnect all power sources and take all the necessary preventive safety measures.

As well as operating frequencies, the operations described below indicate the qualifications that staff must possess in order to perform the operation.

13.1.3 Replacing fuses

Some protection fuses are located on the power board (see wiring diagrams) accessible by dismantling the weight shelf). If fuses require replacement, use ones with an identical current intensity.

14.0 DISPOSAL



CAUTION

The instructions in this chapter are indicative. Refer to the regulations in force in the country where the equipment is used.

14.1 Disposing of the balancer

The balancer must be disposed of after dismantling the various parts.

For disposal operations, as well as wearing the Personal Protective Equipment indicated in the INSTALLATION MANUAL, refer to the instructions and diagrams in this manual. If necessary, request specific information from the manufacturer.

Once you have removed the various parts and components, separate them into the different types of materials according to the differentiated waste disposal regulations in force in the country where the machine is dismantled.

If the various components must be stored before being taken to the dump, make sure to keep them in a safe place protected from atmospheric agents in order to prevent them from contaminating the ground and the water table.

14.2 Disposing of electronics components



Community directive 2002/96/EC, assimilated in Italy with legislative decree n° 151 of 25th July 2005, requires electrical and electronic equipment manufacturers and users to comply with a number of obligations concerning the collection, treatment, recovery and disposal of this waste.

Please scrupulously comply with these waste disposal regulations.

Remember that abusive dumping of this waste leads to the application of the administrative penalties established by current law.

15.0 SPARE PARTS

15.1 Identification and ordering method

The various parts can be identified using the drawings and diagrams in the machine technical file which is archived by the Manufacturer to which a request can be made.

For off-the-shelf parts, the technical manuals or the supplier's original documents can be provided if the Manufacturer deems this to be useful.

If not supplied, this documentation is also included in the machine Technical File, archived by the Manufacturer, as regards by Ministerial Decree 98/37/EC.

In this case, contact the Technical Service to identify the required piece.

If the required pieces are not in any position or they cannot be identified, contact the Technical Service, specifying the type of machine, its serial number and year of construction.

This information is indicated on the machine identification plate.

16.0 ATTACHED DOCUMENTATION

If not supplied, this documentation is included in the Technical File of the machine, archived by the Manufacturer.

In this case, contact the Technical Service for detailed information concerning the machine.